

KDC-V6017, V6090R/RV KDC-V7018R

SERVICE MANUAL

KDC-V6017

ESCUTCHEON ASSY (B07-3007-03) FRONT GLASS (B10-3266-01) PANEL ASSY (A64-2164-02)

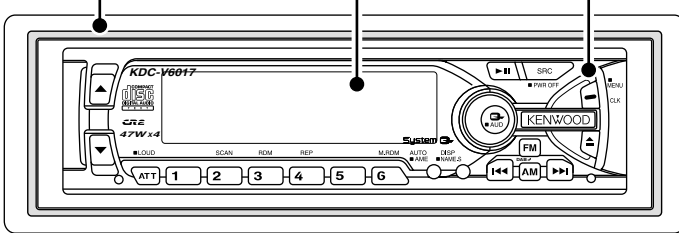

KDC-V6090R/RV

ESCUTCHEON ASSY (B07-3007-03) FRONT GLASS (B10-3274-01) PANEL ASSY (A64-2172-02)

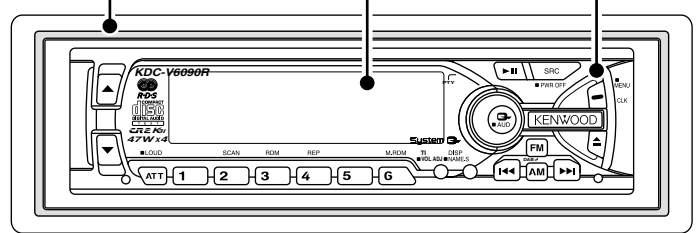

KDC-V7018R

ESCUTCHEON ASSY (B07-3007-03) FRONT GLASS (B10-3270-01) PANEL ASSY (A64-2168-02)

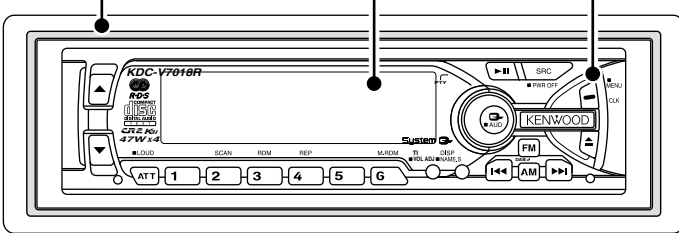

PLASTIC CABINET ASSY (A02-1497-03)

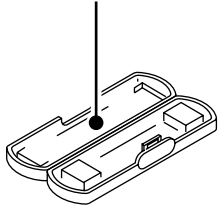

MOUNTING HARDWARE ASSY (J21-9641-13)

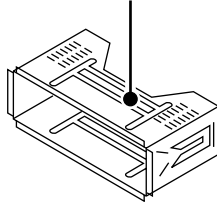

REMOTE CONTROLLER ASSY (A70-0883-05)
: KDC-V6017
KDC-V7018R

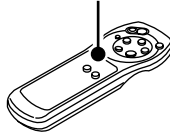

ANTENNA ADAPTOR (T90-0523/0534-05)
: KDC-V6090R/RV

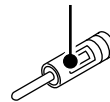

ESCUTCHEON (B07-3010-02)
: KDC-V6017
KDC-V7018R

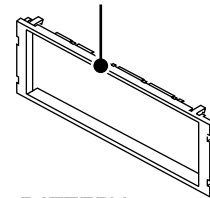

STAY (J54-0606-04)
: KDC-V6017
KDC-V7018R

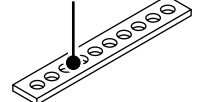

LEVERx2 (D10-4562-04)

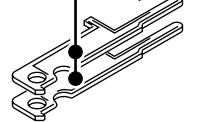

DC CORD (E30-4940-05)
: KDC-V6017

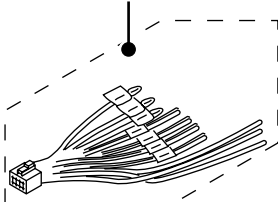

DC CORD (E30-4941-05)
: KDC-V7018R

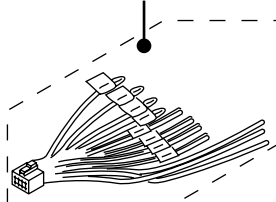

DC CORD (E30-4943-05)
: KDC-V6090RV
(E30-4957-05)
: KDC-V6090R

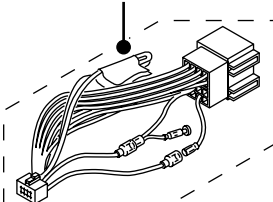

BATTERY (SIZE: AAA)
Not supplied as service parts



SCREW SET (N99-1704-05)



SCREW SET (N99-1700-05)
: KDC-V6017
KDC-V7018

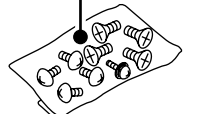

The MECHANISM OPERATION DESCRIPTION is the same as model KDC-S3007 and KDC-5050RG.
Please refer to the service manual for model KDC-S3007(B51-7029-00) or KDC-5050RG(B51-7099-00).



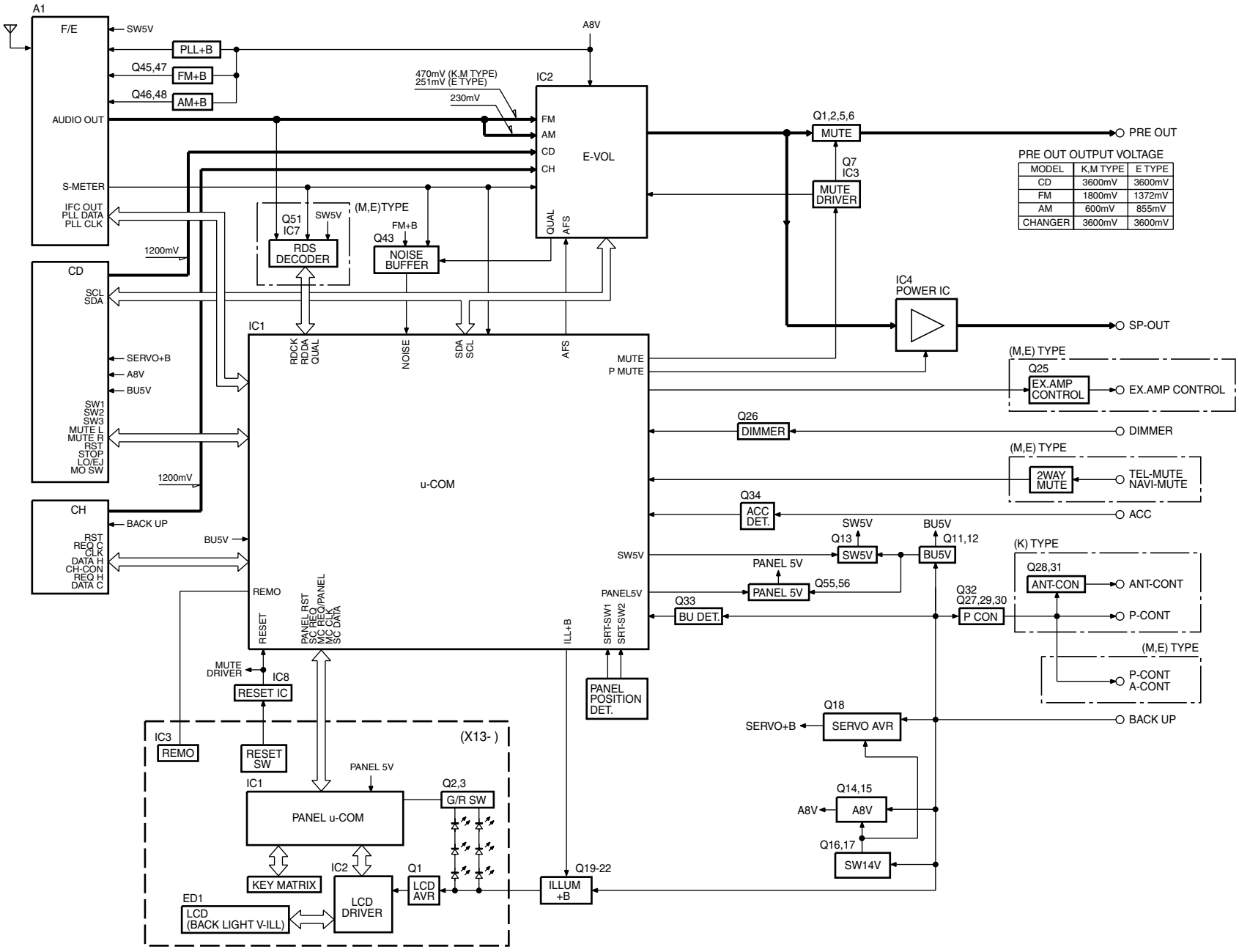

KDC-V6017, V6090R/RV, V7018R
BLOCK DIAGRAM

KDC-V6017, V6090R/RV, V7018R

COMPONENTS DESCRIPTION

● SWITCH UNIT (X13-99XX-XX)

Ref.No.	Component Name	Application/Function	Operation/Condition/Compatibility
IC1	UPD780076GK501	Panel MI-COM.	
IC2	LC75878W	LCD driver	
IC3	RS-171	Remote sensor IC	
Q1	2SC2412K or 2SD601A	VLCD AVR	
Q2	2SD2114K	Green LED SW	When a base goes "Hi", GREEN LEDs are turned on.
Q3	2SD2114K	Red LED SW	When a base goes "Hi", RED LEDs are turned on.
Q4	DTA144EUA or KRA304	REMO SW	While a base goes "Lo", PAN 5V is supplied to the Remote sensor IC.
Q5	2SC2412K or 2SD601A	CONT R SW	When a base goes "Hi", RED LEDs are turned on.
Q6	2SC2412K or 2SD601A	CONT G SW	When a base goes "Hi", GREEN LEDs are turned on.
Q7	2SC2412K or 2SD601A	CONT B SW	When a base goes "Hi", BLUE LEDs are turned on.

● ELECTRIC UNIT (X25-87XX-XX)

Ref.No.	Component Name	Application/Function	Operation/Condition/Compatibility
IC1	UPD703033GC076	System MI-COM.	
IC2	TDA7407D	E.VOL & N.C.MPX IC	
IC3	HD74HC02FP or TC74HC02AF	Mute logic	2-input NOR x 4
IC4	TA8263BH	Power AMP. IC	
IC7	TDA7479D	RDS decoder	
IC8	S-80837ANNP	Reset IC	When BU 5V voltage is less than 3.7V, IC outputs "Lo".
Q1	DTC143TUA or KRC410	Pre mute (Front L)	When Q1's base goes "Hi", Pre-output is muted.
Q2	DTC143TUA or KRC410	Pre mute (Front R)	When Q2's base goes "Hi", Pre-output is muted.
Q5	DTC143TUA or KRC410	Pre mute (Rear L)	When Q5's base goes "Hi", Pre-output is muted.
Q6	DTC143TUA or KRC410	Pre mute (Rear R)	When Q6's base goes "Hi", Pre-output is muted.
Q7	DTA124EUA or KRA303	Mute driver	When BU detection SW or System RESET or MI-COM.'s Pre-mute is working, a base goes "Lo", and Q7 is turned on.
Q11	2SC4081 or 2SD1819A	BU 5V AVR	While BACKUP is applied, AVR outputs +5V.
Q12	2SB1548(P)		Q11 and Q12 are inverted Darlington connection.
Q13	2SA1576A or 2SB1218A	SW 5V	While a base goes "Lo", SW 5V is supplied to the microprocessor peripheral circuits.
Q14	2SC4081 or 2SD1819A	A8V AVR	When Q14's base goes "Hi", A8V AVR outputs 8V.
Q15	2SB1548(P)		
Q16	DTC124EUA or UN5212	SW14V SW	A8V AVR and SERVO +B AVR ON/OFF control
Q17	DTA124EUA or KRA303		While Q16's base goes "Hi", Q17 is turned on, A8V AVR and SERVO +B AVR are working.
Q18	2SD2375	SERVO +B AVR	When Q18's base goes "Hi", SERVO +B AVR outputs 8V.
Q19	DTC124EUA or UN5212	ILL +B SW	ILL +B AVR ON/OFF control
Q20	DTA124EUA or KRA303		While Q19's base goes "Hi", Q20 is turned on, and ILL +B AVR is working.
Q21	2SB1184	ILL +B AVR	While Q22's base goes "Hi", AVR outputs +10.5V.
Q22	2SC4081 or 2SD1819A		Works during POWER ON mode with a panel attached to the set.

COMPONENTS DESCRIPTION

Ref.No.	Component Name	Application/Function	Operation/Condition/Compatibility
Q25	DTA123JK or KRA105S	EXT. AMP CON. SW	When a base goes "Lo", Q25 is turned on.
Q26	DTC144EUA or UN5213	Small lamp detection SW	When vehicle small lamps turn on, Q26 is turned on .
Q27	DTC114YUA or UN5214	P-CON SW	When Q27's base goes "Hi", Q32 is turned on .
Q32	2SB1277(Q,R)		Works during POWER ON mode.
Q29	DTA124EUA or KRA303	P-CON. protection inhibit SW	Prevents Q30 tuning ON during start-up after power ON.
Q30	2SA1576A or 2SB1218A	P-CON. protection SW	Protect Q32 by turning ON when P-CON output is grounded.
Q28	DTC114YUA or UN5214	ANT-CON. SW	When Q28's base goes "Hi", Q31 is turned on.
Q31	2SB1277(Q,R)		Works during TUNER mode.
Q33	2SC4081 or 2SD1819A	BU detection SW	While BACKUP is applied, a base goes "Hi", and Q33 is turned on. When momentary power down has detected, a base goes "Lo", and Q33 is turned off.
Q34	2SC4081 or 2SD1819A	ACC detection SW	While ACC is applied, a base goes "Hi", and Q34 is turned on.
Q42	DTC124EUA or UN5212	E. VOL mute SW	When BU detection SW or MI-COM.'s mute is working, a base goes "Hi", and Q42 is turned on.
Q43	2SC4081 or 2SD1819A	Noise buffer	
Q45	DTC124EUA or UN5212	FM +B SW	When Q45's base goes "Hi", Q47 is turned on .
Q47	2SB1277(Q,R)		Works during FM reception mode.
Q46	DTC124EUA or UN5212	AM +B SW	When Q46's base goes "Hi", Q48 is turned on .
Q48	2SB1277(Q,R)		Works during AM reception mode.
Q51	DTC144EUA or UN5213	IFC buffer	Waveform shaping
Q52	2SC4081 or 2SD1819A	Composite signal output buffer	
Q55	2SA1576A or 2SB1218A	PAN 5V SW	While a panel is attached to the set, Q55's base goes "Hi",
Q56	DTC124EUA or UN5212		and Q55 is turned on.

● CD PLAYER UNIT (X32-5030-00)

Ref.No.	Component Name	Application/Function	Operation/Condition/Compatibility
IC1	AN22000AA	RF amplifier	Generation of RF signal based on the signals from the APC circuit and pickup, and generation of servo error (focusing error and tracking error)signals. Detection of dropout, anti-shock, track crossing and off-track conditions, Gain control function building in.
IC2	MN662773KF1	CD signal processor built-in MI-COM.	
IC4	BA5917AFP	4CH BTL driver	Focusing coil, tracking coil, spindle motor and sled motor driver
IC5	TA78L05AFP	5V AVR	AVR outputs +5V for D/A converter analogue part.
IC6	NJM4565MD	OP Amp.	Low pass filter
Q1	MCH6101	APC	LD power control
Q2	DTC124EUA	P ON SW	When CD source is selected, Q2's base goes "Hi", Q3 and Q4 are turned on.
Q3	2SA1362(Y)	A.8V SW	A8V ON/OFF control. When a base goes "Lo", Q3 is turned on.
Q4	2SA1362(Y)	D.5V SW	D5V ON/OFF control. When a base goes "Lo", Q4 is turned on.
Q5	DTC124EUA	MOTOR SW	When CD loading or eject operation is activating, Q5's base goes "Hi", Q4 is turned on.

MICROCOMPUTER'S TERMINAL DESCRIPTION

● IC1 (SWITCH UNIT : X13-99XX-XX)

Pin No.	Pin Name	I/O	Description	Processing Operation
1	REMO ON	O	Remote sensor IC on/off control	"Lo": PAN 5V is supplied to the Remote sensor IC.
2	RED	O	Red LED on/off control	"Hi": Red LEDs are turned on.
3	GREEN	O	Green LED on/off control	"Hi": Green LEDs are turned on.
4	KR5	I	Key return 5	
5	KR4	I	Key return 4	
6	KR3	I	Key return 3	
7	KR2	I	Key return 2	
8	KR1	I	Key return 1	
9	AVSS	-	Ground connection terminal	Connected to GND lines.
10	VDD	-	Positive power supply connection terminal	Connected to PAN 5V lines.
11	KS4	O	Key scan 4	
12	KS3	O	Key scan 3	
13	KS2	O	Key scan 2	
14	KS1	O	Key scan 1	
15	MC DATA	I	Data input from system MI-COM.	
16	SC DATA	I/O	Data output to system MI-COM.	
17	MC CLK	I	Clock input from system MI-COM.	
18	L CE	O	CE output to LCD driver IC	
19	L DATA	O	Data output to LCD driver IC	
20	L CLK	O	Clock output to LCD driver IC	
21	NC	O		Not used(N.C.)
22	TYPE	I	Destination type input terminal	Not used(pull down to GND lines)
23	L INH	O	Inhibit output to LCD driver IC	"Lo": LCD indication off
24	VDD	-	Positive power supply connection terminal	Connected to PAN 5V lines.
25	AVSS	-	Ground connection terminal	Connected to GND lines.
26	NC	I		Not used (connected to GND lines)
27	NC	I		Not used (connected to GND lines)
28	NC	I		Not used (connected to GND lines)
29	NC	I		Not used (connected to GND lines)
30	NC	I		Not used (connected to GND lines)
31	NC	I		Not used (connected to GND lines)
32	NC	I		Not used (connected to GND lines)
33	NC	I		Not used (connected to GND lines)
34	AVREF	I	A/D converter reference voltage input terminal	Connected to GND lines.
35	NC	O		Not used (N.C.)
36	RESET	I	Reset input	"Lo": Panel MI-COM. reset
37	XT2	-	Sub clock resonator connection terminal	Not used (N.C.)
38	XT1	I	Sub clock resonator connection terminal	Not used (connected to PAN 5V lines)
39	TEST	I	Test terminal	Not used (connected to GND lines)
40	X2	-	Main clock resonator connection terminal	
41	X1	I	Main clock resonator connection terminal	
42	VSS	-	Ground connection terminal	Connected to GND lines.
43	MC REQ	I	Request input from system MI-COM.	
44	SC CON	I	Panel MI-COM. on/off control	"Hi": Operation mode, "Lo": Standby mode
45	SRC	I	SRC key detection	"Hi": SRC key pressed
46	OPEN-EJECT	I	OPEN-EJECT key input	"Hi": EJECT key pressed
47	CONT G	O	Green LED control output for variable illumination	
48	SC REQ	O	Request output to system MI-COM.	
49	NC	O		Not used(N.C.)
50	CONT B	O	Blue LED control output for variable illumination	
51	NC	O		Not used(N.C.)
52	CONT R	O	Red LED control output for variable illumination	
53	EJECT	I	EJECT key detection	"Hi": EJECT key pressed
54	NC	O		Not used(N.C.)
55	NC	O		Not used(N.C.)
56	NC	O		Not used(N.C.)
57	NC	O		Not used(N.C.)
58	NC	O		Not used(N.C.)

MICROCOMPUTER'S TERMINAL DESCRIPTION

Pin No.	Pin Name	I/O	Description	Processing Operation
59	NC	O		Not used(N.C.)
60	NC	O		Not used(N.C.)
61	NC	O		Not used(N.C.)
62	NC	O		Not used(N.C.)
63	NC	O		Not used(N.C.)
64	NC	O		Not used(N.C.)

● IC1 (ELECTRIC UNIT : X25-87XX-XX)

Pin No.	Pin Name	I/O	Description	Processing Operation
1	AM+B	O	AM+B control	"Hi": During AM reception.
2	FM+B	O	FM+B control	"Hi": During FM reception, "Hi": Last FM mode (only RDS model)
3	AFS	O	Noise detection time constant switching terminal	"Hi": During FM reception, "Lo": During FM seek or AF search
4	PLL-DATA	I/O	Data input/output with F/E	
5	PLL-CLK	I/O	Clock input/output with F/E	
6	EVDD	-	Power supply connection terminal	Connected to BU 5V lines.
7	EVSS	-	Ground connection terminal	Connected to GND.
8	NC	O		Not used(N.C.)
9	BEEP	O	BEEP sound output	
10	REMO	I	Data input from the remote control light sensor	
11	CH-REQH	O	Request output to changers	"Lo": Request
12	CH-RST	O	Reset output to changers	 : Reset
13	IC2-SDA	I/O	Data line with IC2, IC5 and CD MECHA. MI-COM.	
14	IC2-CLK	I/O	Clock line with IC2, IC5 and CD MECHA. MI-COM.	
15	CH-MUTE	I	Mute request from changers	"Hi": Mute request
16	CH-CON	O	Changer control	"Hi": Operation mode, "Lo": Standby mode
17	DIMMER-CON/ SC-CON	O	Panel MI-COM. ON/OFF control	"Hi": POWER ON mode "Lo": POWER OFF mode or panel detached or panel mask position
18	TEST	-	Test terminal	Not used(Connected to GND)
19	P-MUTE	O	Power IC mute control output	"Lo": Mute (POWER OFF, TEL MUTE)
20	P-STBY	O	Power IC standby control output	"Hi": POWER ON mode except panel detached or panel mask position
21	MUTE	O	IC2 mute control output	"Hi": Mute on
22	NC	O		Not used(N.C.)
23	PRE-MUTE	O	Pre-output Mute control output	"Lo": Mute
24	ACC-DET	I	ACC detection input	"Hi": ACC OFF, "Lo": ACC ON
25	DIMMER	I	Small lights detection input	"Lo": During vehicle small lamps turn on.
26	SW5V	O	SW 5V control output	"Lo": POWER ON mode or during CD loading/eject action
27	EXT-AMP-CON	O	External amp. control output	Bass boost OFF__"Hi": 160msec, "Lo": 40msec Bass boost LOW__"Hi": 130msec, "Lo": 70msec Bass boost HI__"Hi": 100msec, "Lo": 100msec
28	P-CON	O	Power control output	"Hi": POWER ON mode except ALL OFF mode
29	ANT-CON	O	Antenna control output	"Hi": During FM/AM reception or TI reception
30	P-ON	O	SW 14V control output	"Hi": POWER ON mode or during CD loading/eject action
31	RESET	I	Reset input terminal	"Lo": System reset
32	XT1	I	Sub clock resonator connection terminal	Clock count during POWER OFF mode
33	XT2	-	Sub clock resonator connection terminal	
34	REGC	-	C terminal	
35	X2	-	Main clock resonator connection terminal	Oscillation stop: POWER OFF mode or momentary power down detected
36	X1	I	Main clock resonator connection terminal	
37	VSS	-	Ground connection terminal	Connected to GND lines.
38	VDD	-	Power supply connection terminal	Connected to BU 5V lines.
39	CLKOUT	O	Internal system clock output	
40	NC	O		Not used(N.C.)
41	NC	O		Not used(N.C.)
42	TYPE0	I	Destination type input terminal 0	
43	TYPE1	I	Destination type input terminal 1	
44	TYPE2	I	Destination type input terminal 2	

MICROCOMPUTER'S TERMINAL DESCRIPTION

Pin No.	Pin Name	I/O	Description	Processing Operation
45	TYPE3	I	Destination type input terminal 3	
46	IC2TYPE0	I	IC2 setting terminal	"Lo": Initial value
47	IC2TYPE1	I	IC2 setting terminal	"Lo": Initial value
48	NC	O		Not used(N.C.)
49	NC	O		Not used(N.C.)
50	NC	O		Not used(N.C.)
51	NC	O		Not used(N.C.)
52	ILL-ON	O	Illumination AVR ON/OFF control output	"Hi": POWER ON mode except panel detached or panel mask position
53	M-MUTE L	I	Mute request (Lch) from CD MECHA. MI-COM.	"Lo": Mute request
54	M-MUTE R	I	Mute request (Rch) from CD MECHA. MI-COM.	"Lo": Mute request
55	BVDD	-	Power supply connection terminal	Connected to BU 5V lines.
56	BVSS	-	Ground connection terminal	Connected to GND lines.
57	M-RST	O	Reset output to CD MECHA. MI-COM.	"Lo": Reset
58	M-STOP	O	Stop request to CD MECHA. MI-COM.	"Lo": Stop mode, "Hi": Operation mode
59	NC	O		Not used (N.C.)
60	LO/EJ	I/O	CD MECHA. loading/Eject switching output	"Lo": Loading, "Hi": Eject, "Hi-Z": Stop or Break
61	MOSW	O	CD mechanism loading motor control output	"Hi": CD loading/eject action or Break, "Lo": other
62	NC	O		Not used (N.C.)
63	CD-SW3	I	Down & limit switch detection input	"Hi": Chucking, "Lo": Pickup most inner position
64	P-RESET	O	Reset output to panel MI-COM.	"Lo": Reset
65	L-CE/MC REQ/PANEL	I/O	Request output to panel MI-COM.	
66	NC	O		Not used (N.C.)
67	NC	O		Not used (N.C.)
68	NC	O		Not used (N.C.)
69	NC	O		Not used (N.C.)
70	AVCONT	O	A/D converter reference voltage control output	"Hi": Active, Connected to AVREF terminal.
71	AVDD	-	A/D converter power supply connection terminal	Connected to BU 5V lines.
72	AVSS	-	A/D, D/A converter ground connection terminal	Connected to GND.
73	AVREF	I	A/D converter reference voltage input terminal	
74	PHONE	I	PHONE detection input	1V or less: TEL MUTE, 2.5V or greater: NAVI MUTE
75	NC(GND)	I		Not used (pull down to GND lines)
76	NC(GND)	I		Not used (pull down to GND lines)
77	SRT-SW2	I	SRT position detection input	Panel: (SW1, SW2)=(Hi, Hi), Slide: (SW1, SW2)=(Hi, Lo)
78	SRT-SW1	I	SRT position detection input	Mask : (SW1, SW2)=(Lo, Lo)
79	NOISE	I	FM noise detection input	
80	S-METER	I	S-meter input from F/E	
81	R-DATA	I	Data input from the RDS decoder IC	Except RDS model: Not used(pull down to GND lines)
82	R-QUAL	I	Quality input from the RDS decoder IC	Except RDS model: Not used(pull down to GND lines)
83	IFC-OUT	I	IFC OUT of the F/E input terminal	"Hi": Station detected, "Lo": Not detected
84	NC(GND)	I		Not used (pull down to GND lines)
85	NC(GND)	I		Not used (pull down to GND lines)
86	NC	O		Not used (N.C.)
87	R-CLK	I	Clock input from the RDS decoder IC	Except RDS model: Not used (pull down to GND lines)
88	CH-REQC	I	Request input from changers	"Lo": Request
89	KEY-REQ/SC-REQ	I	Communication request input form panel MI-COM.	
90	CD-SW1	I	Loading detection	"Lo": CD chucking.
91	CD-SW2	I	12cm disc detection terminal	When 12cm disc was detected, the input becomes "Lo" temporarily.
92	NC	O		Not used (N.C.)
93	BU-DET	I	Momentary power down detection input	"Hi" : When momentary power down detected or BU OFF "Lo" : BU ON
94	CH-DATAC	I	Data input from changers	
95	CH-DATAH	O	Data output to changers	
96	CH-CLK	I/O	Clock input/output with changers	
97	L-DATAL/SC-DATA	I	Data input from panel MI-COM.	
98	L-DATAS/MC-DATA	I/O	Data output to panel MI-COM.	
99	L-CLK/PANEL/MC-CLK	I/O	Clock output to panel MI-COM.	
100	PAN5V	O	Panel 5V control	"Hi": Panel attached, "Lo": Panel detached

TEST MODE

TEST MODE

1. How to enter the test mode

While holding the FM and Preset 6 keys, reset the unit.

2. How to exit from the test mode

While holding the Preset 6 key, reset the unit.

(Note) The test mode cannot be terminated by ACC OFF, power OFF or momentary power down.

3. Initial status in the test mode

- Sources : ALL OFF
- Display : All segments are lit.
- Volume : -10 dB (displayed as "30")
- Loudness : OFF
- CRSC : OFF regardless of the presence of switching function.
- SYSTEM Q : Flat
- LED : White for no scanning. (VLCD model)

4. Special display in Tuner mode

When any of the following messages is displayed in Tuner mode, the F/E may be abnormal.

- "TNE2P NG" : The EEPROM is set to the default (unstable values) because the F/E was shipped without passing through the adjustment process, etc.
- "TNCON NG" : Communication with the F/E is not possible.

5. Forced switching of K3I

Each press of the Preset 6 key in Tuner mode should switch K3I from AUTO → Forced Wide → Forced Middle → Forced Narrow → AUTO.

The initial status is AUTO and the display shows these modes as follows.

- AUTO : FMA
- Forced Wide : FMW
- Forced Middle : FMM
- Forced Narrow : FMN

6. Test mode specifications of the CD receiver

- Forced ejection is inhibited in the reset start operation. When the unit is reset while a CD is loaded in it, the CD is not recognized by resetting.
- Each press of the Track Up key jumps to the following track numbers:
No. 9 → No. 15 → No. 10 → No. 11 → No. 12 → No. 13 → No. 14 → No. 9
(The cycle restarts from here.)
- Each press of the Track Down key jumps to the previous track number to the track being played.

7. Audio-related specifications

- A short press of the Q key initiates the audio adjustment mode.
- Pressing the * key on the remote initiates the audio adjustment mode.
- Continuous holding of a remote control key is inhibited.
- Bass, Middle and Treble are adjusted in 3 steps of Min/Center/Max with the Track Up/Down keys.

- Balance is adjusted in 3 steps of Left Max/Center/Right Max with the Track Up/Down keys.
- Fader is adjusted in 3 steps of Rear Max/Center/Front Max with the Track Up/Down keys.
- HPF is adjusted in 2 steps of Through/220 Hz with the Track Up/Down keys.
- LPF is adjusted in 2 steps of Through/120 Hz with the Track Up/Down keys.
- Bass f, Bass Q, Bass EXT, Middle f, Middle Q and Treble f are not dealt with by the audio adjustment.

8. Menu-related specifications

- A short press of the CLK key initiates the Menu mode.
- Pressing the DNPP/SBF key on the remote initiates the Menu mode.
- Continuous holding of a remote control key is inhibited.
- Calendar adjustment, calendar display switching and calendar memo are eliminated from the targets of continuous key holding. (FL model)
- In the color adjustment mode, pressing the Preset 1 key sets Red, 2 sets Blue, 3 sets Green and 4 sets Green. (VLCD model)
- Contrast is adjusted in 3 steps of 0/5/10 and the default is 5. (VLCD/LCD model)
- Brightness is adjusted in 3 steps of 0/5/10 and the default is 10. (Normal FL model)

9. Backup current measurement

When the unit is reset while ACC is OFF (i.e. by turning Backup ON), the MUTE terminal goes OFF in 2 seconds in place of 15 second. (The panel, CD mechanism and TAPE mechanism are not activated at this time.)

10. Special display when the display is all on

Pressing the Preset keys while the power is ALL OFF displays the following information.

[PRESET 1]	Version display (8 digits, Month/Day/Hour/Minute) (Display) SYS xxxxxxxx System microcomputer PAN xxxxxxxx Panel microcomputer
[PRESET 2]	Serial No. display (8 digits) (Note) CD/RK type eXcelon model (Display) S. No. xxxxxxxx
[PRESET 3]	Short press : View power ON time. (The All OFF period is not counted.) Long press/hold : Clear power ON time. (Display) PonTim xxxxx Max. 65535 (hours)
[PRESET 4]	Short press : Display TAPE/CD/MD operation time. Long press/hold : Clear TAPE/CD/MD operation time (Display) CDTim xxxxx (CD/R) TapTim xxxxx (C/R) Max. 65535 (hours)
[PRESET 5]	Short press : Display TAPE/CD/MD ejection count. Long press/hold : Clear TAPE/CD/MD ejection count. (Display) EjeTim xxxxx Max. 65535 (times)
[PRESET 6]	Short press : Display Panel open/close count. Long press/hold : Clear Panel open/close count. (Display) PnCnt xxxxx Max. 655350 (times)

TEST MODE

11. Other specifications

- Automatic panel closing when a tape/CD is inserted is inhibited. (M&T model)
- Panel operation by turning power OFF/ON is inhibited. (M&T model)
- Messages such as "CODE OFF" are not displayed when power is turned ON.
- Pressing the ATT key opens or closes the panel. (M&T model)
- Pressing the TI (AUTO) key during changer operation turns 2zone ON. 2zone can be turned OFF by pressing the TI (AUTO) key again. The P/S dot lights while 2zone is ON.
- Pressing and holding the CLK key for a second in the ALL OFF status the Mask Key (security) write mode.

• Security-related information

1. Forced Power ON mode (All models)

Even when the security (Mask key) is approved, resetting the unit while holding the ATT and Preset 4 keys makes it possible to turn the power ON for 30 minutes. After 30 minutes have elapsed, it is not possible to return to the previous condition unless the unit is reset again.

2. Method of registration of the security code after EEPROM (Tuner Unit Ass'y) replacement (Code security model)

- (1) Enter the test mode. (See " 1. How to enter the test mode")
- (2) Press the CLK key to enter the security registration mode.
- (3) Enter the code using the Preset 1/2/3/4 keys.
Example: To enter "3510"
 - Press the Preset 1 key 4 times.
 - Press the Preset 2 key 6 times.
 - Press the Preset 3 key twice.
 - Press the Preset 4 key once.
- (4) Press and hold the DISP key for 3 seconds until "APPROVED" is displayed.
- (5) Exit from the test mode. (See " 2. How to exit from the test mode")

(Note) All Clear is not applicable to the security code of this model.

3. Simplified method of clearing the security code (K Type only)

- (1) While the code entry is requested, press and hold the VOL UP key for 3 seconds while holding the DISP key pressed. (This should turn "----" off.)
- (2) Enter "KCAR" from the remote. (Same way as the 00 model)
Press the 5 key on the remote twice, then press the Track Up key. (This enters "K".)
Press the 2 key on the remote 3 times, then press the Track Up key. (This enters "C".)
Press the 2 key on the remote once, then press the Track Up key. (This enters "A".)
Press the 7 key on the remote twice, then press the Track Up key. (This enters "R".)

(3) The security code is cleared and the unit enters the ALL OFF mode.

(4) If you commit a mistake in the code entry, the unit enters the code request mode again.

4. Method of writing the Mask key while the EEPROM is in the initial status

- (1) Enter the test mode. (See " 1. How to enter the test mode")
 - (2) Press the CLK key to enter the Mask key registration mode. "TRANSMIT1" should be displayed now. The display at this time should show " < > " in place of " [] ".
 - (3) Point the Mask key remote toward the light sensor, and press and hold its key for more than 0.5 second.
 - (4) When "TRANSMIT2" is displayed, press and hold the key on the Mask key remote for more than 0.5 second again. The first and second counter codes are not compared at this time.
 - (5) When "APPROVED" is displayed, the write operation is complete. Now the demonstration mode is initiated and the test mode is terminated.
- (Note) In the same way as previous models, if 30 minutes have elapsed with no code written, an error occurs and the power is turned OFF.

5. Method of initializing the Mask key

(How to reset the unit from the Mask key approved condition to the factory condition)

- (1) Enter the test mode. (See " 1. How to enter the test mode")
- (2) "TRANSMIT1" is displayed and the Mask key entry request mode is initiated.
The display at this time should show " * * " in place of " [] ".
- (3) Press and hold the key on the Master key remote for more than 3 seconds.
- (4) When "TRANSMIT2" is displayed, press and hold the key on the Master key remote for more than 3 seconds again.
- (5) When "APPROVED" is displayed, the Mask key is cleared, the demonstration mode is initiated, the test mode is terminated and the unit returns to the factory condition.

6. Method of clearing all Mask key-related data

- (1) Enter the test mode. (See " 1. How to enter the test mode")
- (2) Press the CLK key to enter the Mask key registration mode. "TRANSMIT1" should be displayed now.
- (3) Point the Master key remote toward the light sensor, and press and hold its key for more than 3 seconds (until the level display shows the full condition).
- (4) When "TRANSMIT2" is displayed, hold the key on the Mask key remote for more than 3 seconds again. If "TRANSMIT1" is displayed in place of "TRANSMIT2", restart the procedure from step (3).
- (5) When "APPROVED" is displayed, all security data is cleared and the unit returns to the condition before Mask key writing with the EEPROM in the initial status.

ATTENTION

assembly of FPC(Flexible PC board) onto Roller ass'y

Turn Roller ass'y by 2 times.

Hook the end of Roller ass'y to the tongue.

Insert the FPC into the slit of Roller ass'y then release the end of Roller ass'y and the tongue.

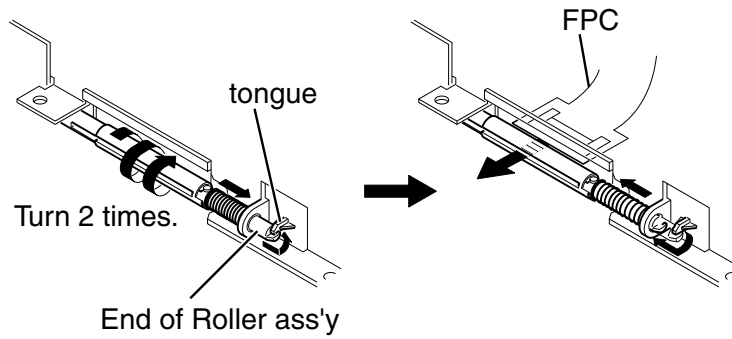

PC BOARD (COMPONENT SIDE VIEW)

X32-5030-00 (J74-1160/1161-02)

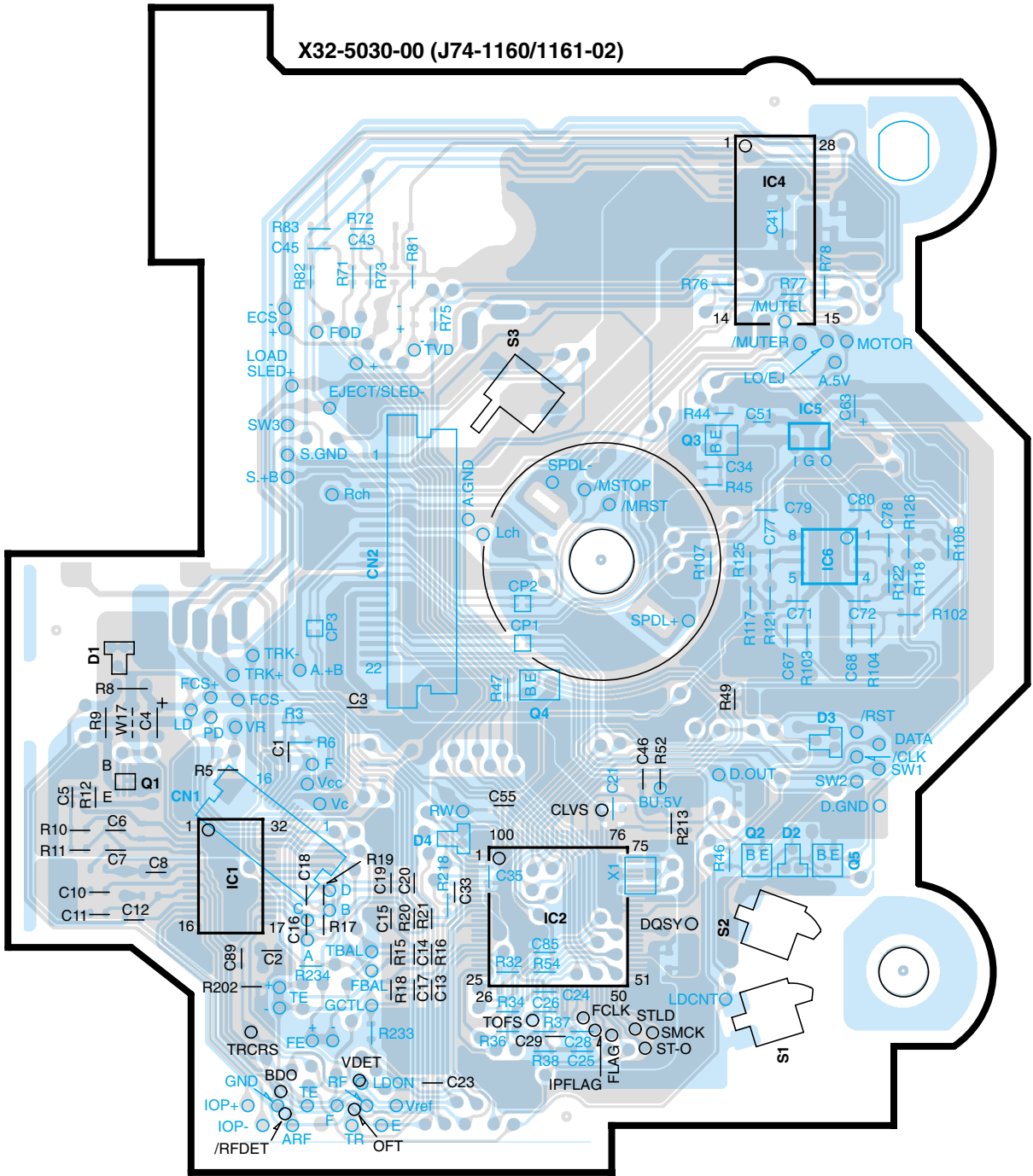

X32-5030-00

IC	1	2	4	5	6					
Q						1	2	3	4	5
Address	5B	5C	2D	3D	4D	5A	5D	3D	4C	5D

PC BOARD (FOIL SIDE VIEW)

X32-5030-00 (J74-1160/1161-02)

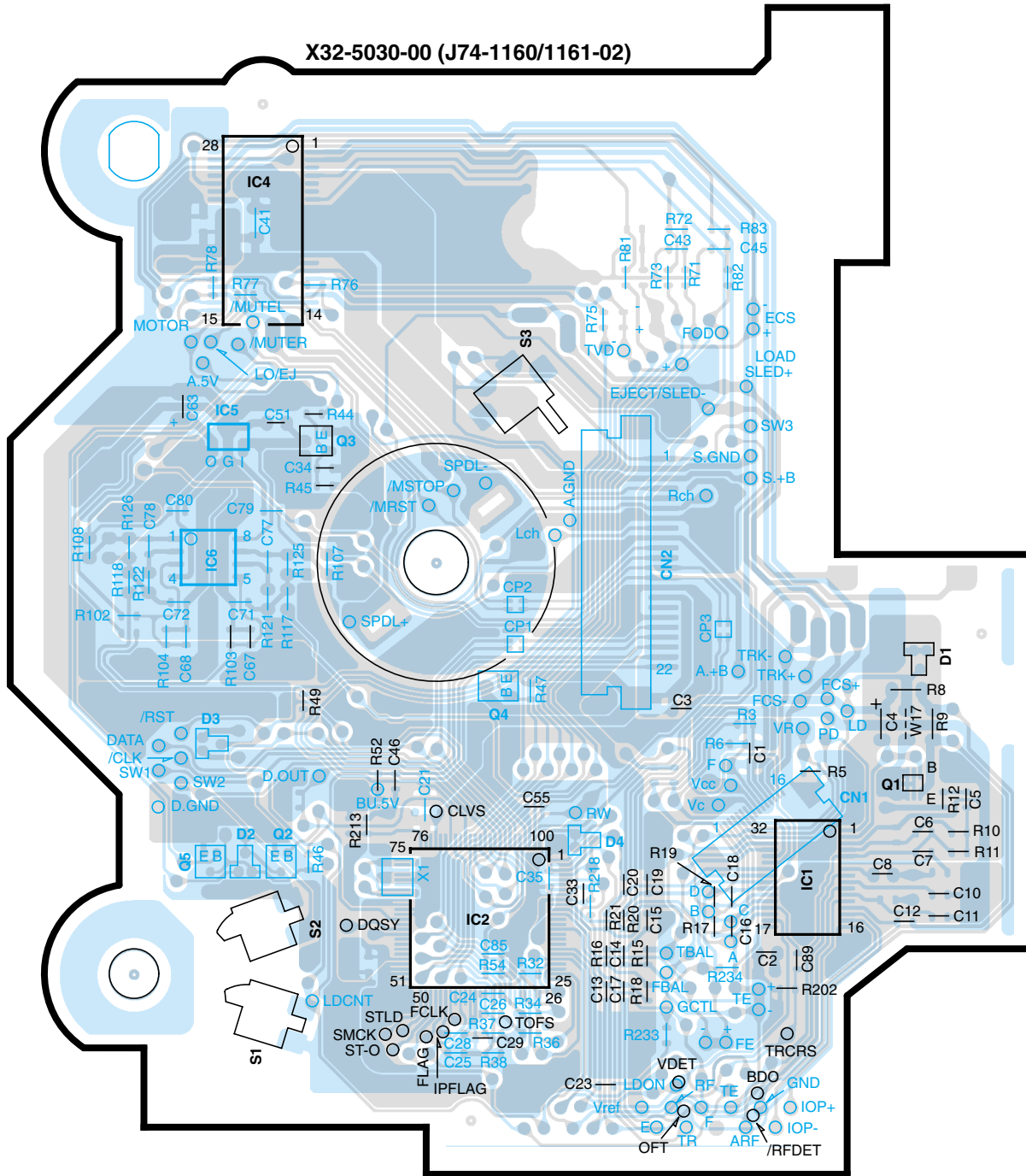

X32-5030-00

IC	1	2	4	5	6					
Q						1	2	3	4	5
Address	5I	5H	2G	3G	4G	5J	5G	3G	4H	5G

PC BOARD (COMPONENT SIDE VIEW)

X13-9950-10/9982-70 A/2 (J74-1136-12)

X25-877X-XX (J74-1144-12)
X25-8782-72 (J74-1219-12)

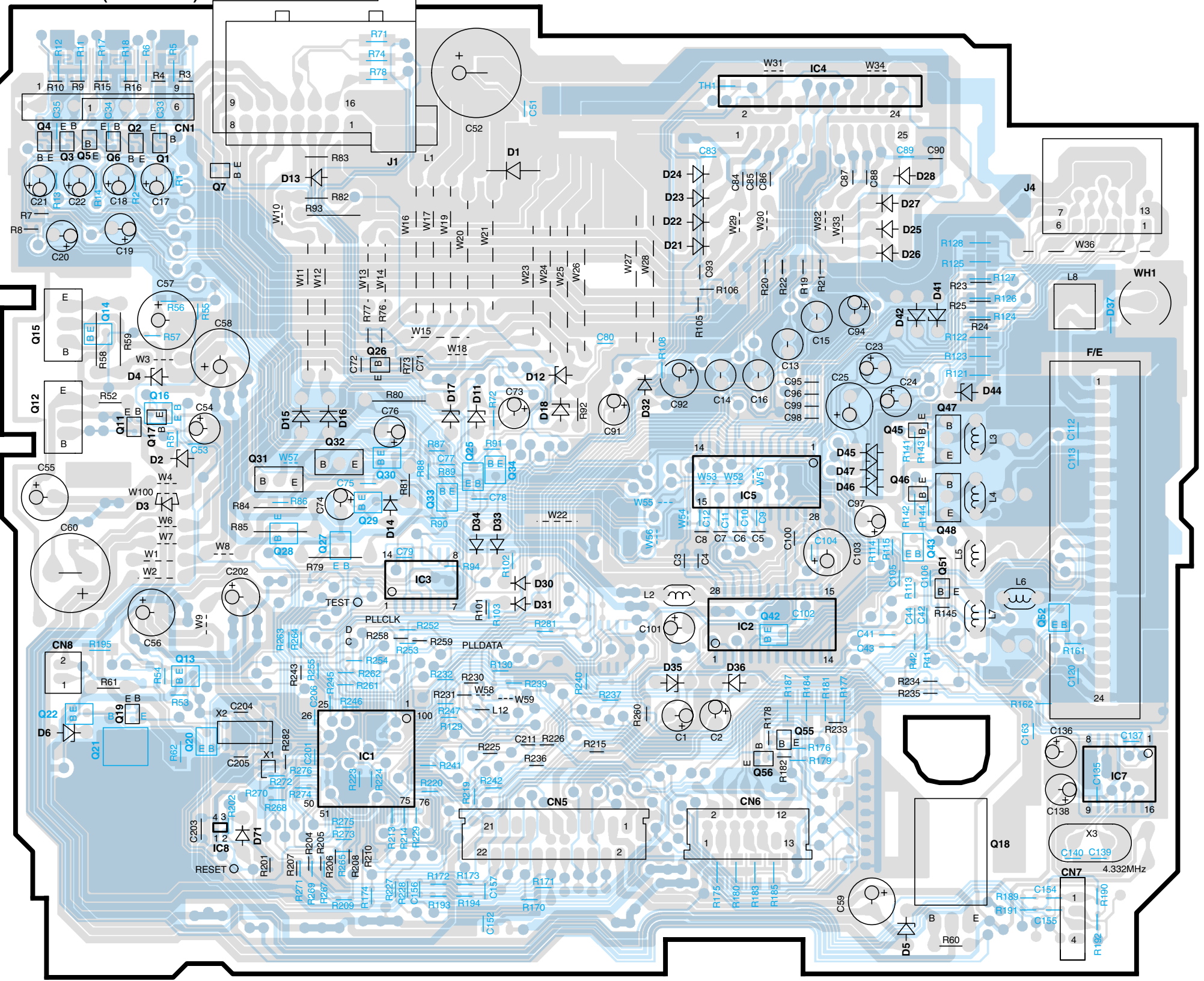
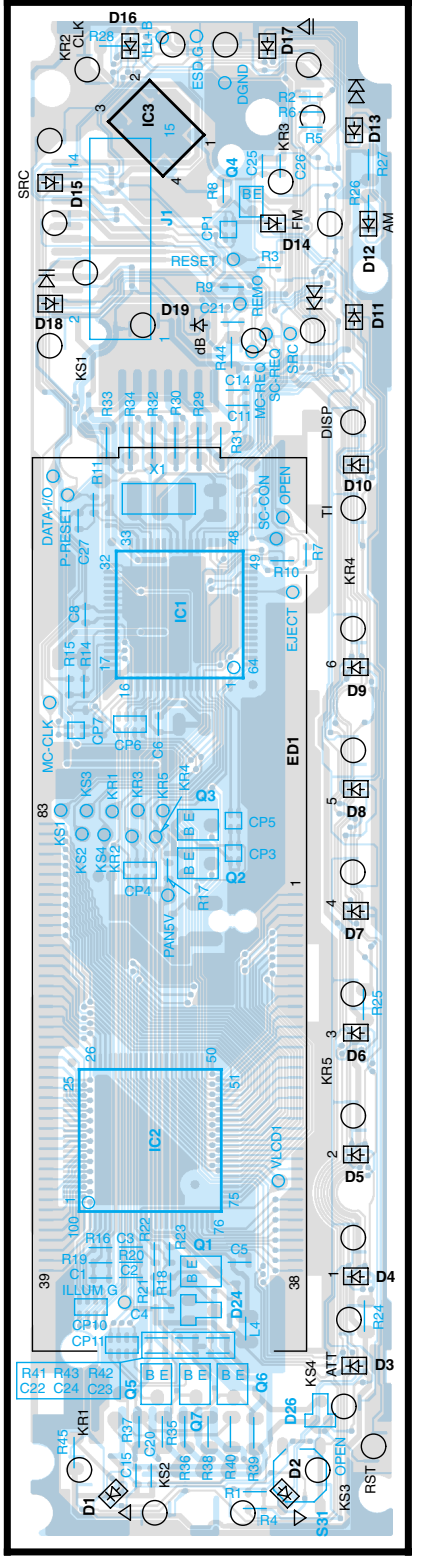
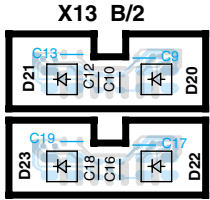

X13-99XX-XX

IC	Q
1	3L
2	5L
3	2L
1	5L
2	4L
3	4L
4	2L
5	6L
6	6L
7	6L

X25-87XX-XX

IC	Q
1	5O
2	5Q
3	4O
4	2R
7	6S
8	6N
1	2N
2	2N
5	2M
6	2N
7	2N
11	4N
12	3M
13	5N
14	3N
15	3M
16	3N
17	4N
18	6S
19	5N
20	5N
21	5M
22	5M
25	4P
26	3O
27	4O
28	4O
29	4O
30	4O
31	4N
32	4O
33	4O
34	4P
42	5Q
43	4R
45	4R
46	4R
47	3R
48	4R
51	4R
52	5S
55	5Q
56	5Q

Refer to the schematic diagram for the values of resistors and capacitors.

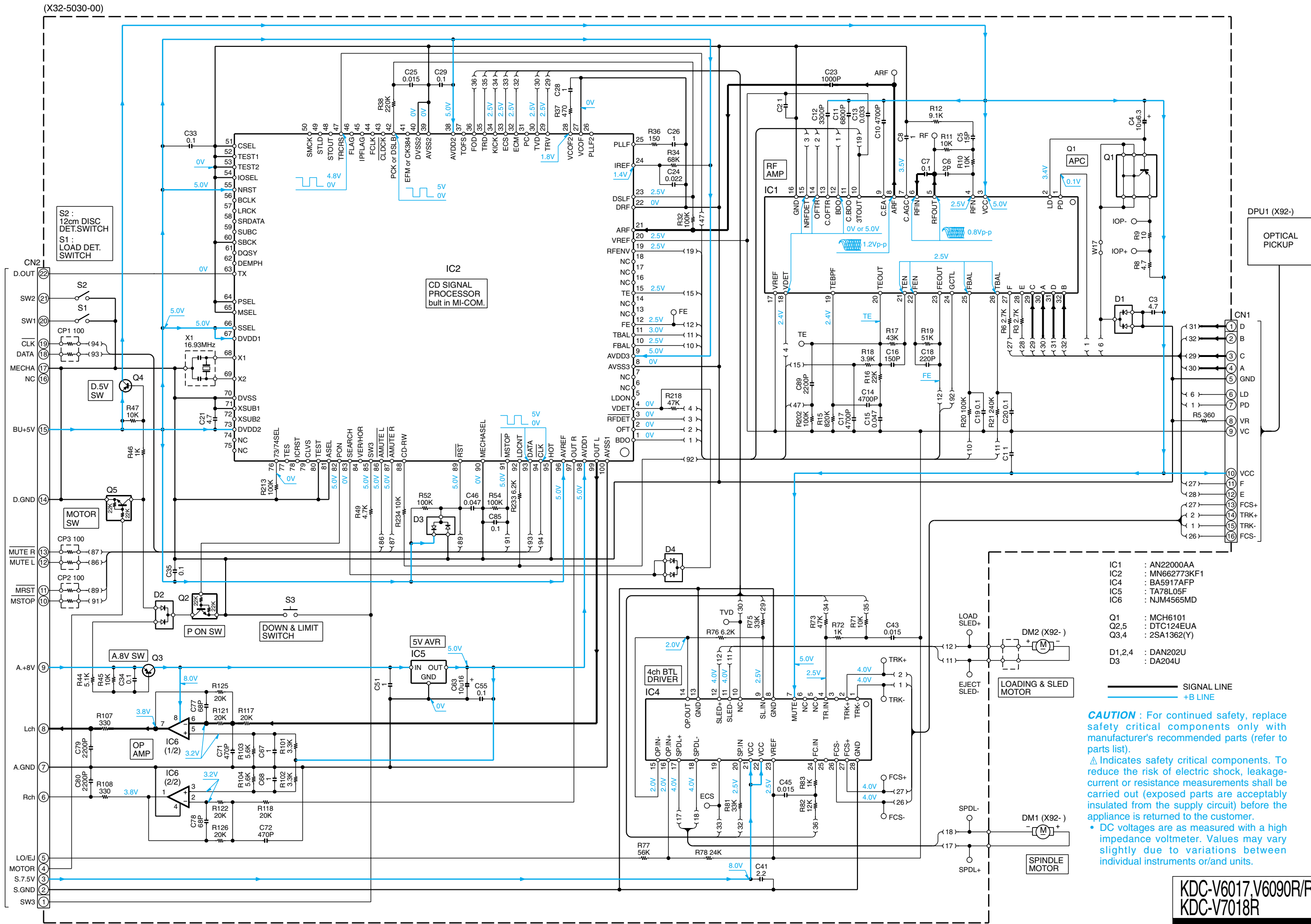

- IC1 : AN22000AA
- IC2 : MN662773KF1
- IC4 : BA5917AFP
- IC5 : TA78L05F
- IC6 : NJM4565MD

- Q1 : MCH6101
- Q2,5 : DTC124EUA
- Q3,4 : 2SA1362(Y)
- D1,2,4 : DAN202U
- D3 : DA204U

— SIGNAL LINE
 — +B LINE

CAUTION : For continued safety, replace safety critical components only with manufacturer's recommended parts (refer to parts list).

⚠ Indicates safety critical components. To reduce the risk of electric shock, leakage-current or resistance measurements shall be carried out (exposed parts are acceptably insulated from the supply circuit) before the appliance is returned to the customer.

- DC voltages are as measured with a high impedance voltmeter. Values may vary slightly due to variations between individual instruments or/and units.

KDC-V6017,V6090R/RV
 KDC-V7018R

KENWOOD

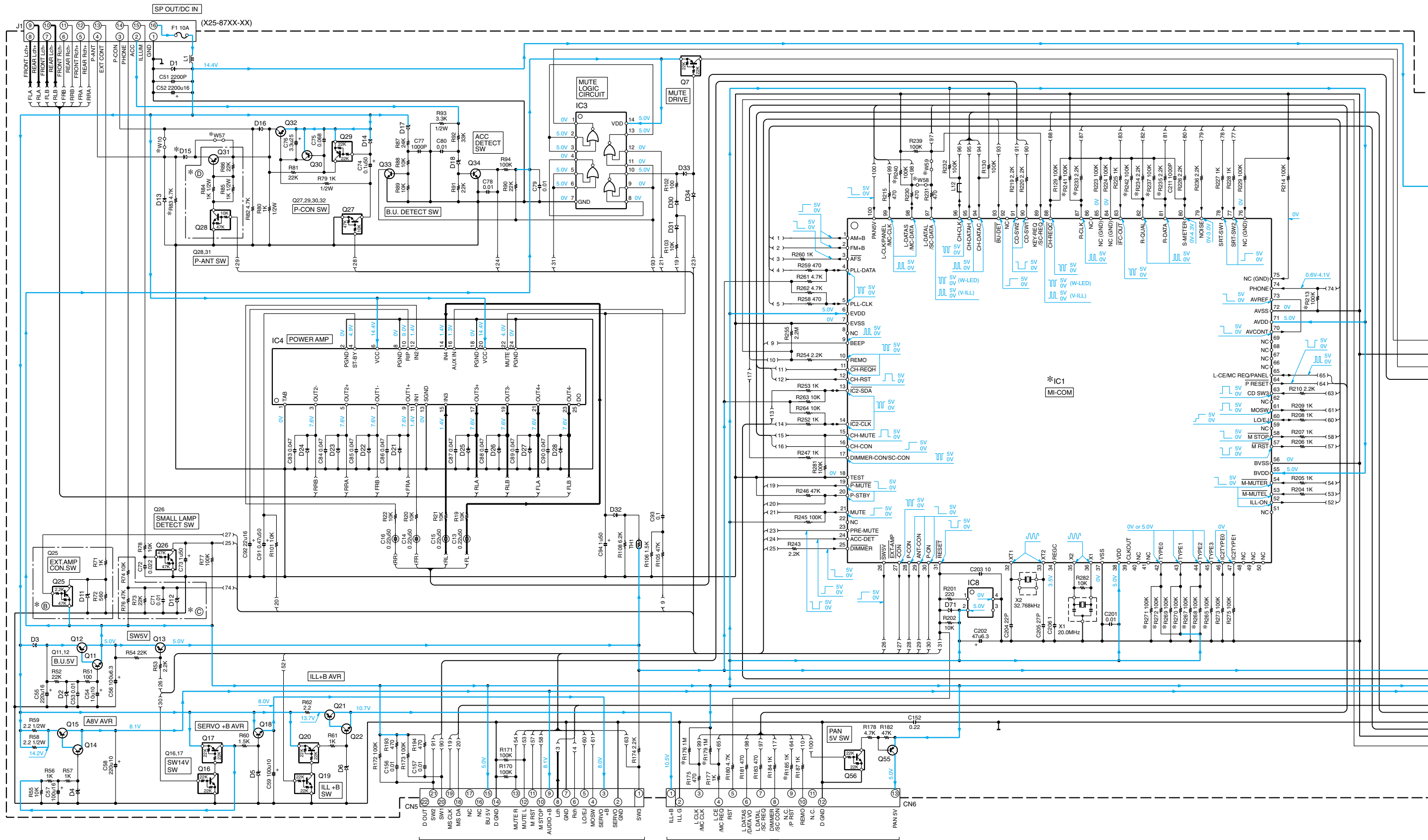

to CD MECHA. (X32.)

- UN5214
- 2SA1362
- 2SA1576A
- 2SB1218A
- 2SC2412K
- 2SD1819
- A
- 2SD2114
- K
- E
- C
- 2SB118
- 4
- 2SB154
- 8
- 2SB127
- 7
- 2SC4081
- DTA124EUA
- DTC124EUA
- DTC144EUA

CAUTION: For continued safety, replace safety critical components only with manufacturer's recommended parts (refer to parts list).

▲ Indicates safety critical components. To reduce the risk of electric shock, leakage-current or resistance measurements shall be carried out (exposed parts are acceptably insulated from the supply circuit) before the appliance is returned to the customer.

- DC voltages are as measured with a high impedance voltmeter. Values may vary slightly due to variations between individual

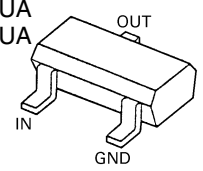

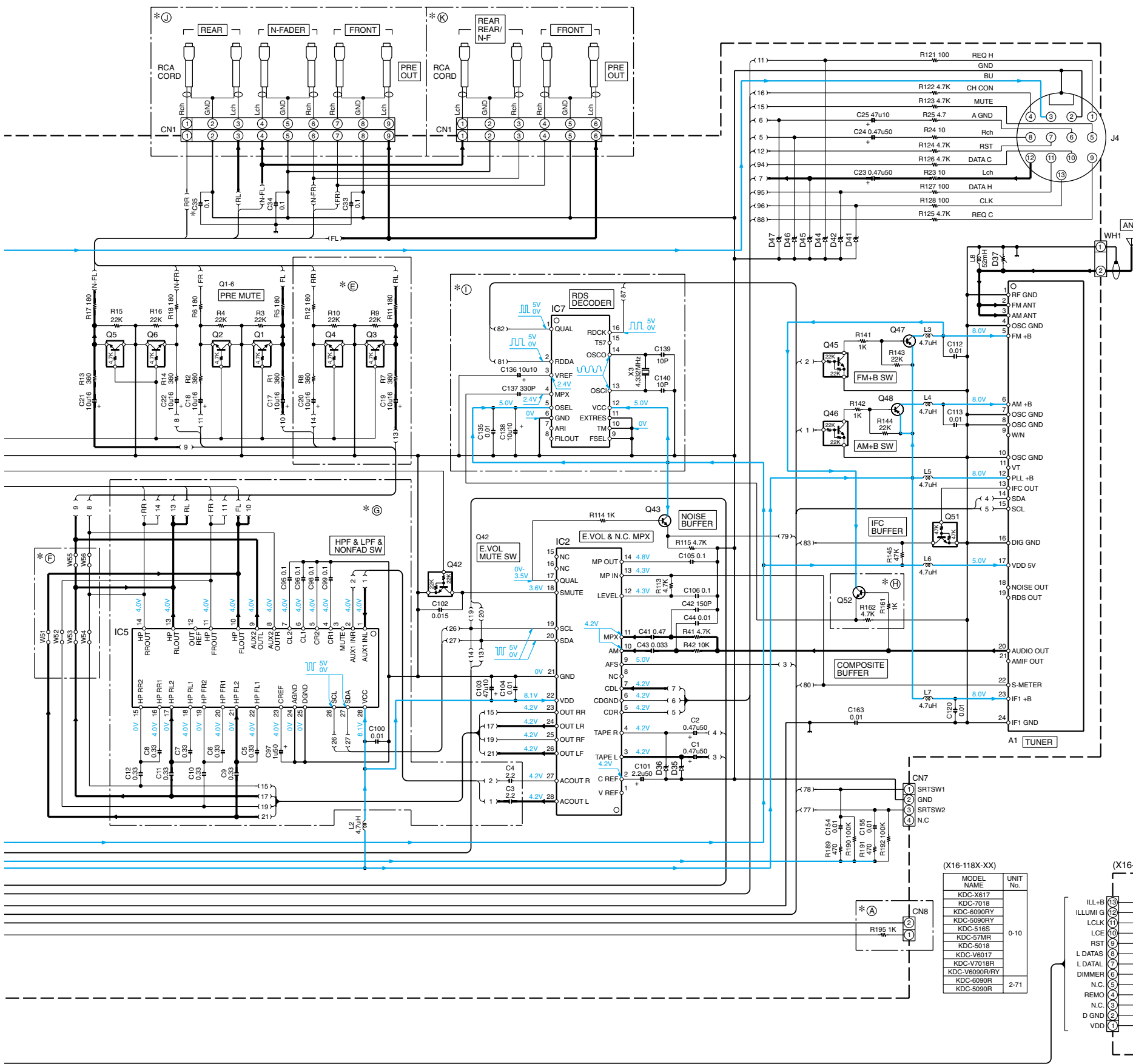

(X25-87XX-XX)

MODEL NAME	UNIT No.	A	B	C	H	I	D	E	F	J	G	K
KDC-X617	70-10	NO	YES	NO	NO	YES	YES	NO	YES	NO	YES	NO
KDC-7018	70-21	NO	YES	NO	NO	YES	YES	NO	YES	NO	YES	NO
KDC-6090RY	72-71	NO	YES	YES	NO	NO	NO	NO	YES	YES	NO	YES
KDC-6090R	82-70	NO	YES	YES	NO	NO	NO	NO	NO	NO	YES	YES
KDC-5090R	72-72	NO	NO	NO	YES	NO	NO	NO	YES	NO	YES	NO
KDC-5090R	82-71	NO	NO	NO	YES	NO	NO	NO	NO	YES	NO	YES
KDC-V6017	70-11	NO	NO	NO	NO	YES	NO	YES	NO	YES	NO	YES
KDC-V7018R	70-22	NO	YES	YES	NO	NO	NO	NO	YES	NO	YES	NO
KDC-V6090RY	72-73	NO	YES	YES	NO	NO	NO	NO	YES	NO	YES	NO
KDC-V6090R	82-72	NO	YES	YES	NO	NO	NO	NO	YES	NO	YES	NO
KDC-516S	70-12	NO	NO	NO	NO	YES	NO	YES	NO	YES	NO	YES
KDC-5018	70-23	NO	YES	NO	NO	YES	NO	YES	NO	YES	NO	YES
KDC-57MR	70-13	YES	NO	NO	NO	YES	NO	YES	NO	YES	NO	YES

MODEL NAME	D15	C35	IC1	R83	R176, 265	R179, 185, 240	R213, 237, 241, 242
KDC-X617	YES	YES	UPD703033GC057	YES	YES	NO	YES
KDC-7018	YES	YES	UPD703033GC057	YES	YES	NO	YES
KDC-6090RY	YES	NO	UPD703033GC057	YES	YES	NO	NO
KDC-6090R	YES	NO	UPD703033GC057	YES	YES	NO	NO
KDC-5090R	YES	NO	UPD703033GC057	YES	YES	NO	NO
KDC-V6017	YES	NO	UPD703033GC057	YES	YES	NO	NO
KDC-V7018R	YES	NO	UPD703033GC078	YES	NO	YES	YES
KDC-V6090RY	YES	NO	UPD703033GC076	NO	NO	YES	NO
KDC-V6090R	YES	NO	UPD703033GC076	YES	NO	YES	NO
KDC-516S	YES	NO	UPD703033GC057	YES	YES	NO	YES
KDC-5018	YES	NO	UPD703033GC057	YES	YES	NO	YES
KDC-57MR	YES	NO	UPD703033GC057	YES	YES	NO	YES

MODEL NAME	R233-235	R267	R268	R269	R270	R271	R272	W10	W57	W58	W59
KDC-X617	NO	YES	NO	YES	NO	YES	NO	NO	NO	NO	YES
KDC-7018	NO	YES	NO	YES	NO	YES	NO	NO	NO	NO	YES
KDC-6090RY	YES	YES	NO	NO	YES	YES	NO	NO	NO	NO	YES
KDC-6090R	YES	YES	NO	NO	YES	YES	NO	NO	NO	NO	YES
KDC-5090R	YES	YES	NO	NO	YES	YES	NO	NO	NO	NO	YES
KDC-V6017	NO	NO	NO	NO	YES	NO	YES	NO	NO	NO	YES
KDC-V7018R	YES	NO	NO	NO	YES	NO	YES	NO	YES	NO	YES
KDC-V6090RY	YES	NO	NO	NO	YES	NO	YES	NO	NO	YES	NO
KDC-V6090R	YES	NO	NO	NO	YES	NO	YES	NO	NO	YES	NO
KDC-516S	NO	NO	YES	NO	YES	NO	NO	NO	NO	NO	YES
KDC-5018	NO	NO	YES	NO	YES	NO	NO	NO	NO	NO	YES
KDC-57MR	NO	NO	YES	YES	NO	NO	YES	NO	NO	NO	YES

- IC1 : *
- IC2 : TDA7407D
- IC3 : HD74HC02FP or TC74HC02AF
- IC4 : TA8263BH
- IC5 : TDA7401
- IC7 : TDA7479D
- IC8 : S-90837ANNP
- D1 : RM10ZLF
- D2 : MA4056(N)-M
- D3 : 1GWJ43
- D4 : MA4091(N)-L
- D5 : MA4082(N)-L or HZS9A2L
- D6 : MA4110-L or HZS11B2
- D11 : MA4056-M or HZS6B1
- D12 : MA4047-M or HZS5B1
- D13,15,16,21-28 : AM01Z or DSM15D2 or ERA15-02
- D14,30-34,71 : 1SS133
- D17,18,35,36,45-47 : ERA15-02
- D37 : MA4068(N)-M
- D41,42,44 : MA4062-L or HZS6C1
- Q1-6 : DTC143TUA or KRC410
- Q7,17,20,29 : DTA124EUA or KRA303
- Q11,14,22,33,34,43,52 : 2SC4081 or 2SD1819A
- Q12,15 : 2SB1548(P)
- Q13,30,55 : 2SA1576A or 2SB1218A
- Q16,19,42,45,46,56 : DTC124EUA or UN5212
- Q18 : 2SD2375
- Q21 : 2SB1184
- Q25 : DTA123JK or KRA105S
- Q26,51 : DTC144EUA or UN5213
- Q27,28 : DTC114YUA or UN5214
- Q31,32,47,48 : 2SB1277(Q,R)
- R176, R179, R185, 240 : MA4056(N)-M
- R213, R237, R241, 242 : MA4091(N)-L or MA4082(N)-L or HZS9A2L
- R233-235 : MA4110-L or HZS11B2
- R267, R268, R269, R270, R271, R272 : MA4056-M or HZS6B1
- R271, R272 : MA4047-M or HZS5B1
- W10, W57, W58, W59 : AM01Z or DSM15D2 or ERA15-02
- W57, W58, W59 : MA4068(N)-M
- W59 : MA4062-L or HZS6C1

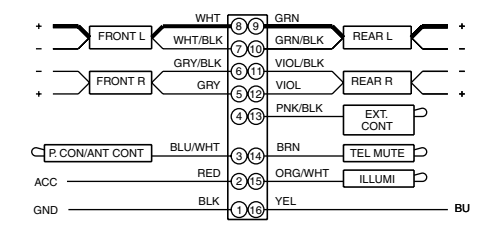

DC CORD (E30-4941-05) KDC-V7018R

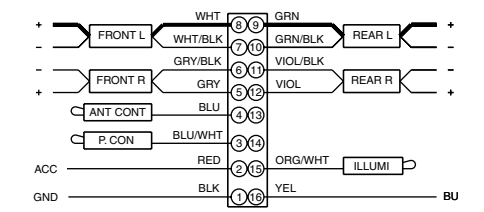

DC CORD (E30-4940-05) KDC-516S/57MR/V6017

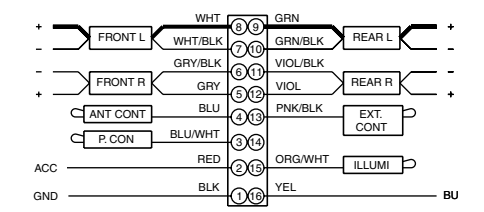

DC CORD (E30-4939-05) KDC-X617/7018/5018R

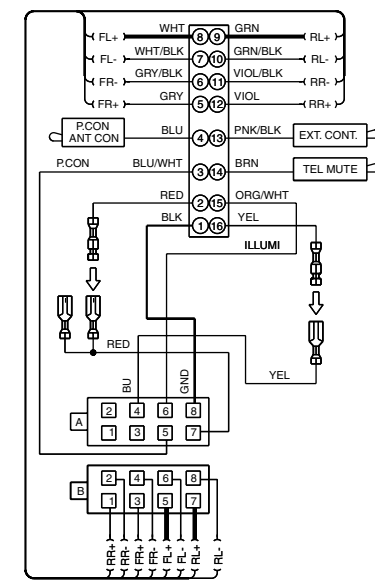

DC CORD (E30-4943-05) KDC-6090RY/V6090RY (E30-4957-05) KDC-6090R/V6090R

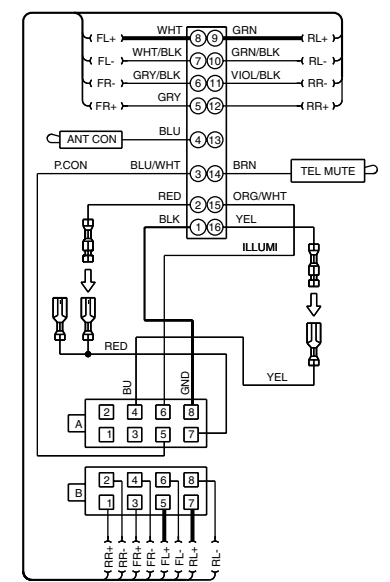

DC CORD (E30-4944-05) KDC-5090RY (E30-4958-05) KDC-5090R

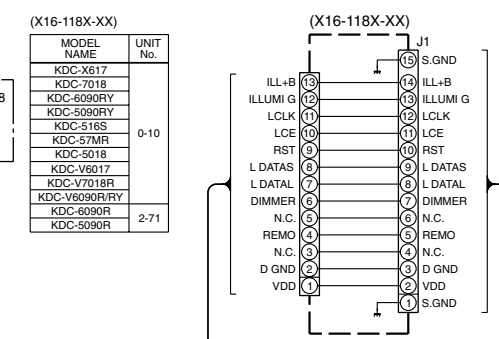
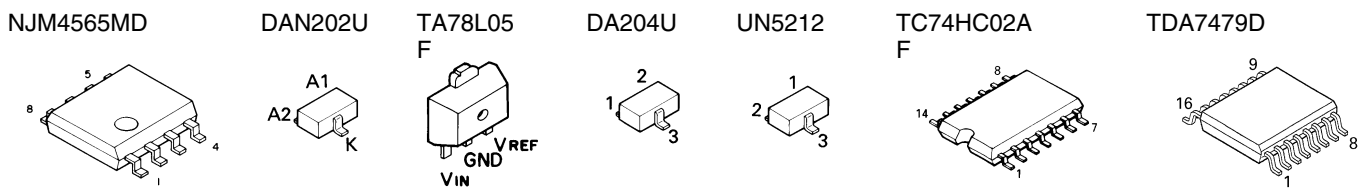

(X16-118X-XX)

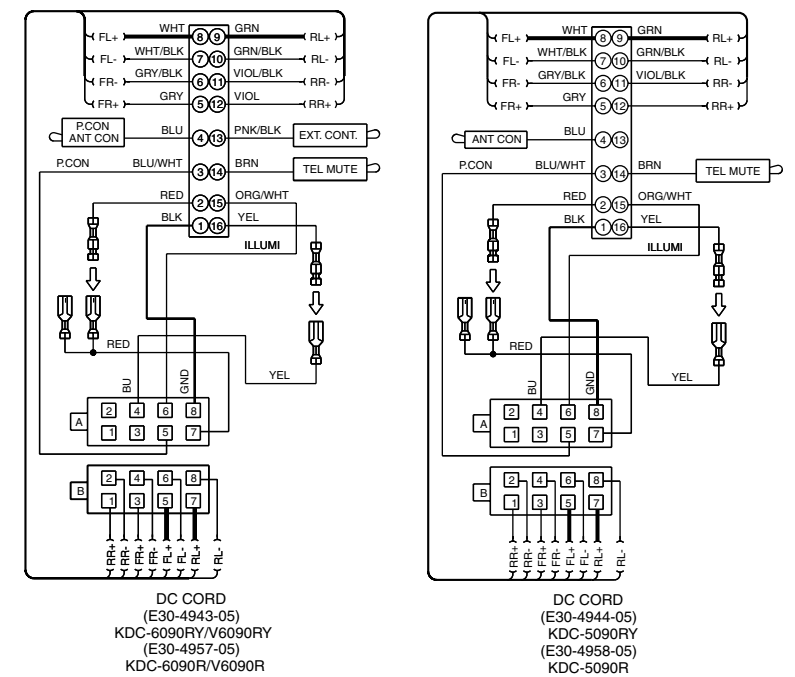

(X13-J1)

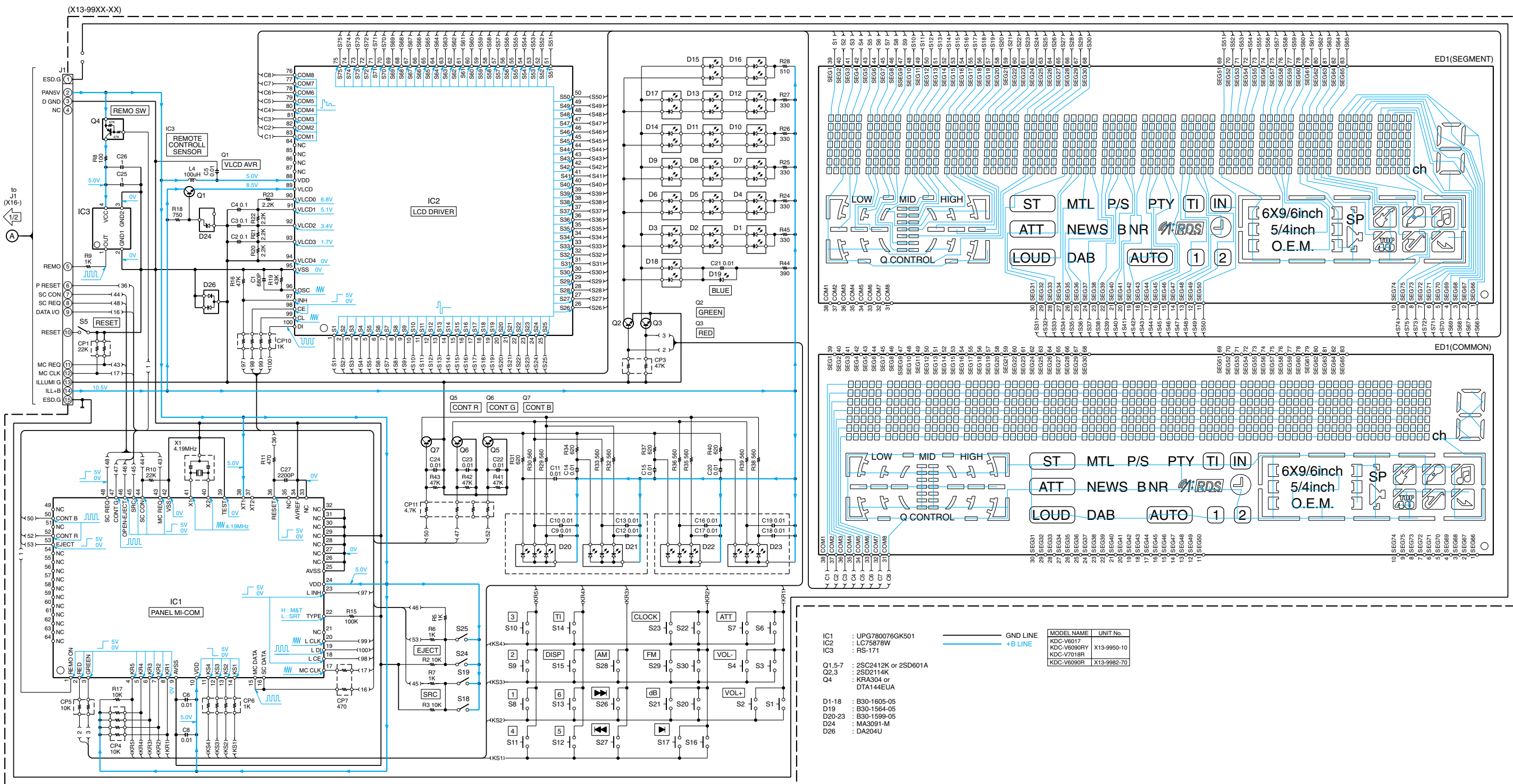

CAUTION: For continued safety, replace safety critical components only with manufacturer's recommended parts (refer to parts list).
 ⚠ Indicates safety critical components. To reduce the risk of electric shock, leakage-current or resistance measurements shall be carried out (exposed parts are acceptably insulated from the supply circuit) before the appliance is returned to the customer.
 • DC voltages are as measured with a high impedance voltmeter. Values may vary slightly due to variations between individual instruments or/and units.

KDC-V6017, V6090R/R
 KDC-V7018R
KENWOOD

EXPLODED VIEW (MECHANISM)

- | | |
|-----------------------|---------------|
| A M1.7x2.5 | : N09-4249-05 |
| B $\phi 2 \times 3.5$ | : N09-4172-05 |
| C M1.7x4 | : N09-4202-05 |
| D M2x2 | : N38-2020-46 |
| E $\phi 2 \times 6$ | : N09-4294-05 |
| F WASHER $\phi 1.2$ | : N19-2023-04 |
| G WASHER $\phi 1.6$ | : N19-2058-04 |
| H WASHER $\phi 1.6$ | : N19-2093-04 |
| J M2x2 | : N39-2020-46 |

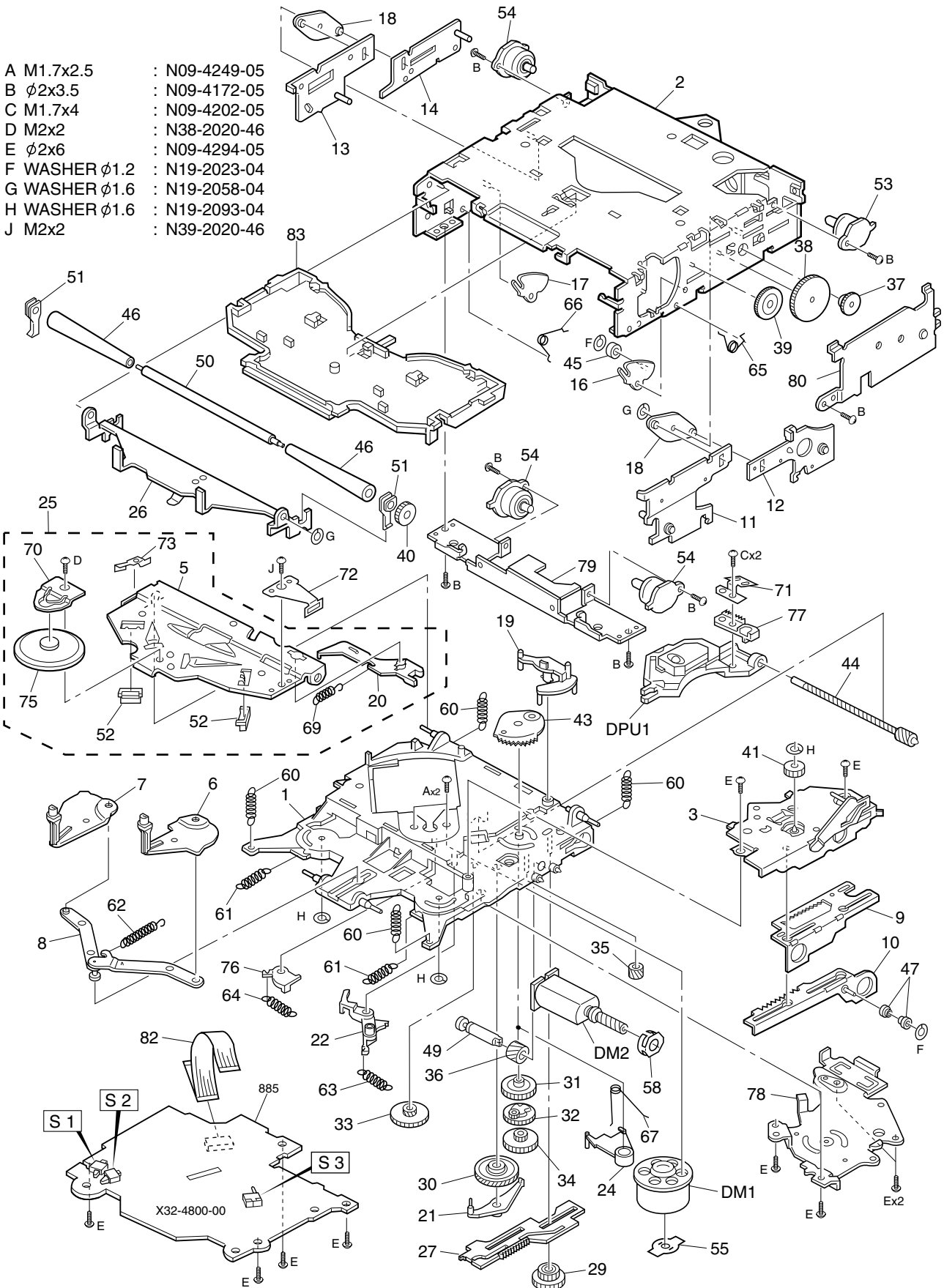

Parts with the exploded numbers larger than 700 are not supplied.

KDC-V6017,V6090R/RV,V7018R

EXPLODED VIEW (UNIT)

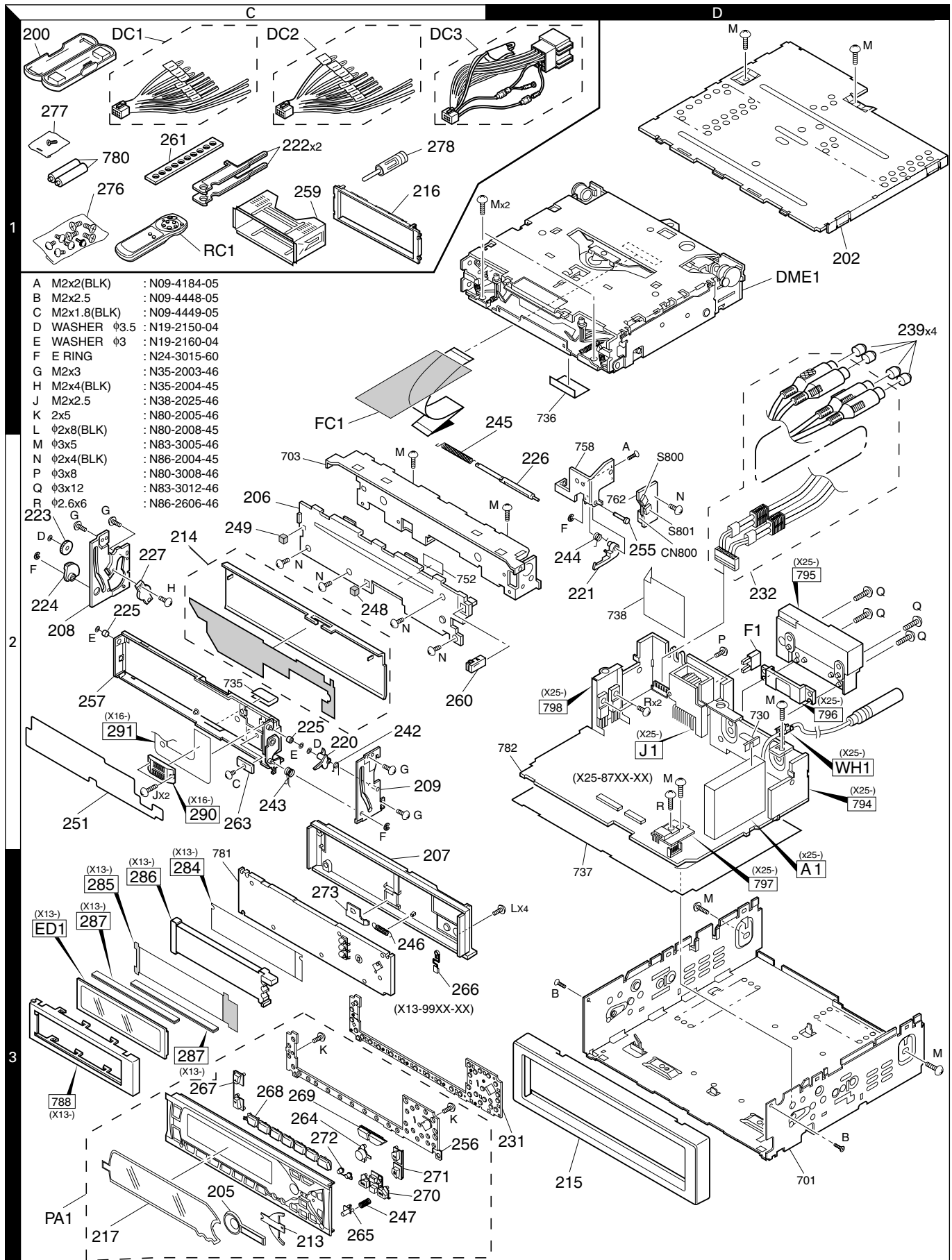

KDC-V6017,V6090R/R,Y,V7018R

PARTS LIST

* New Parts

Parts without **Parts No.** are not supplied.

Les articles non mentionnes dans le **Parts No.** ne sont pas fournis.

Teile ohne **Parts No.** werden nicht geliefert.

Ref. No.	A d d	N e w	Parts No.	Description	Dest inati on	Ref. No.	A d d	N e w	Parts No.	Description	Dest inati on
KDC-V6017,V6090R/R,Y,V7018R						△	F1	2D	F52-0011-05	FUSE(MINI BLADE TYPE) (10A)	K1M2E2
200	1C		A02-1497-03	PLASTIC CABINET ASSY		242	2C	*	G01-3057-04	TORSION COIL SPRING (SW LEVER)	
202	1D	*	A52-0779-02	TOP PLATE		243	2C	*	G01-3058-04	TORSION COIL SPRING (MAIN)	
205	3C		A21-4073-03	DRESSING PANEL		244	2D	*	G01-3059-04	TORSION COIL SPRING (RELEASE)	
206	2C	*	A22-2853-23	SUB PANEL ASSY		245	1D	*	G01-3060-04	TORSION COIL SPRING (FPC ROLL)	
207	3C		A46-1692-01	REAR COVER		246	3C	*	G01-3069-04	EXTENSION SPRING (LOCK)	
208	2C	*	A50-1019-04	SIDE PLATE ASSY (L)		247	3C	*	G01-3070-04	COMPRESSION SPRING (RELEASE)	
209	2C	*	A50-1022-04	SIDE PLATE ASSY (R)		248	2C	*	G11-1919-04	CUSHION (SUB PANEL MIDDLE)	
PA1	3C	*	A64-2164-02	PANEL ASSY	K1	249	2C	*	G11-1920-24	CUSHION (SUB PANEL LEFT)	
PA1	3C	*	A64-2168-02	PANEL ASSY	M2	251	2C	*	G16-1178-04	SHEET (CAUTION)	
PA1	3C	*	A64-2172-02	PANEL ASSY	E2E1	-		*	H10-4762-12	POLYSTYRENE FOAMED FIXTURE	E1
RC1	1C		A70-0883-05	REMOTE CONTROLLER ASSY(RC-500)	K1M2	-		*	H10-4763-12	POLYSTYRENE FOAMED FIXTURE	E2
213	3C	*	B03-3071-03	DRESSING PLATE		-		*	H10-4764-12	POLYSTYRENE FOAMED FIXTURE	K1M2
214	2C	*	B03-3075-02	DRESSING PLATE (BLK)		-		*	H25-0329-04	PROTECTION BAG (280X450X0.03)	K1M2E2
215	3D	*	B07-3007-03	ESCUTCHEON ASSY (BLK)		-		*	H25-0337-04	PROTECTION BAG (180X300X0.03)	
216	1C		B07-3010-02	ESCUTCHEON (J CAR)	K1M2	-			H25-1108-04	PROTECTION BAG (100X300X0.03)	
217	3C	*	B10-3266-01	FRONT GLASS	K1	-			H25-1111-04	PROTECTION BAG (280X450X0.03)	
217	3C	*	B10-3270-01	FRONT GLASS	M2	-		*	H54-2002-03	ITEM CARTON CASE	E1
-			B46-0100-50	WARRANTY CARD	E2E1	-		*	H54-2005-03	ITEM CARTON CASE	E1
-			B46-0606-04	ID CARD	K1M2E1	-		*	H54-2007-03	ITEM CARTON CASE	K1
-			B46-0612-14	ID CARD	K1	-		*	H54-2012-03	ITEM CARTON CASE	M2
-			B46-0632-04	ID CARD	E2E1	255	2D	*	J12-1156-04	PIN (RELEASE)	
-			B58-1376-04	CAUTION CARD		256	3C	*	J19-5036-02	HOLDER	
-		*	B64-1867-00	INST. MANUAL (ENG,RUS,POL)	E2	257	2C	*	J21-9613-12	MOUNTING HARDWARE ASSY (PANEL)	
-		*	B64-1868-00	INST. MANUAL (CZE,HUN,CRO)	E2	259	1C	*	J21-9641-13	MOUNTING HARDWARE ASSY	
-		*	B64-1869-00	INST. MANUAL (SWE,FIN)	E2	260	2C		J52-0604-05	PUSH LATCH	
-		*	B64-1873-00	INST. MANUAL (ENGLISH)	E1	261	1C		J54-0606-04	STAY	K1M2
-		*	B64-1874-00	INST. MANUAL (FRE,GER,DUT)	E1	263	2C	*	J90-0999-04	GUIDE (PANEL MECHA)	
-		*	B64-1875-00	INST. MANUAL (ITA,SPA,POR)	E1	264	3C		K24-3647-04	KNOB (DB)	
-		*	B64-1876-00	INST. MANUAL (ENG,FRE,SPA)	K1	265	3C		K24-3648-04	KNOB (RELEASE)	
-		*	B64-1877-00	INST. MANUAL (ENG,CHI)	M2	266	3C		K24-3658-04	KNOB (RELEASE2)	
-		*	B64-1878-00	INST. MANUAL (ARABIC)	M2	267	3C		K25-1222-03	KNOB (VOL)	
220	2C	*	D10-4557-04	LEVER (SRT POSITION SW)		268	3C		K25-1223-03	KNOB (PRESET)	
221	2D	*	D10-4558-04	ARM (RELEASE)		269	3C		K25-1224-03	KNOB (SRC)	
222	1C	*	D10-4562-04	LEVER		270	3C		K25-1225-03	KNOB (FM,AM)	
222	1C	*	D10-4621-04	LEVER	E1	271	3C		K25-1226-03	KNOB (EJECT)	
223	2C	*	D13-2117-04	GEAR (IDOL)		272	3C		K25-1227-03	KNOB (DISP)	
224	2C	*	D13-2118-04	GEAR (ARM)		273	3C		K29-7017-03	KNOB (LOCK)	
225	2C		D14-0751-04	ROLLER (PANEL)		276	1C		N99-1700-05	SCREW SET	K1M2
226	2D		D14-0752-03	ROLLER (FPC)		277	1C		N99-1704-05	SCREW SET	
227	2C		D39-0244-05	DAMPER		A	2D		N09-4184-05	MACHINE SCREW (M2X2 BLK)	
231	3D		E29-1824-02	CONDUCTIVE RUBBER (KEY)		B	3D		N09-4448-05	MACHINE SCREW (M2X2.5)	
232	2D	*	E30-4935-05	CORD WITH PINPLUG		C	2C		N09-4449-05	MACHINE SCREW (M2X1.8 BLK)	
CN800	2D		E41-0070-05	SOCKET FOR PIN ASSY (4P)		D	2C		N19-2150-04	FLAT WASHER (1.6X3.5X0.25)	
△ DC1	1C		E30-4940-05	DC CORD	K1	E	2C		N19-2160-04	FLAT WASHER (1.2X3.0X0.25)	
△ DC2	1C		E30-4941-05	DC CORD	M2	F	2C		N24-3015-60	E TYPE RETAINING RING	
△ DC3	1C		E30-4943-05	DC CORD	E2	G	2C		N35-2003-46	BINDING HEAD MACHINE SCREW	
△ DC3	1C	*	E30-4957-05	DC CORD	E1	H	2C		N35-2004-45	BINDING HEAD MACHINE SCREW	
△ FC1	1C	*	E39-0375-05	FLAT CABLE		J	2C		N38-2025-46	PAN HEAD MACHIN SCREW	
239	1D		F29-0049-05	INSULATING COVER		K	3C		N80-2005-46	PAN HEAD TAPTITE SCREW	
△ F1	2D		F52-0006-05	FUSE(MINI BLADE TYPE) (10A)		L	3D		N80-2008-45	PAN HEAD TAPTITE SCREW	
						M	1D		N83-3005-46	PAN HEAD TAPTITE SCREW	
						N	2C		N86-2004-45	BINDING HEAD TAPTITE SCREW	

K1: KDC-V6017 E1: KDC-V6090R E2: KDC-V6090RY M2: KDC-V7018R

△ indicates safety critical components.

KDC-V6017,V6090R/RV,V7018R

PARTS LIST

*New Parts

Parts without **Parts No.** are not supplied.

Les articles non mentionnes dans le **Parts No.** ne sont pas fournis.

Teile ohne **Parts No.** werden nicht geliefert.

KDC-V6017,V6090R/RV,V7018R

Ref. No.	A d d	N e w	Parts No.	Description	Dest inati on
S800,801	2D		S68-0830-05	PUSH SWITCH	
278	1C		T90-0523-05	ANTENNA ADAPTOR	E2E1
278	1C		T90-0534-05	ANTENNA ADAPTOR	E2E1
DME1	1D	*	X92-4100-00	MECHANISM ASSY (DXM-1360)	
SWITCH UNIT (X13-99XX-XX)					
284	3C	*	B11-1322-04	REFLECTION SHEET	
285	3C	*	B11-1323-14	OPTICAL DIFFUSER	
286	3C	*	B19-2069-03	LIGHTING BOARD	
D1 -18			B30-1605-05	LED(2COLOR PG/RED)	
D19			B30-1564-05	LED(1608,BLUE)	
D20 -23			B30-1599-05	LED(NICHIA FULL)	
ED1	3C		B38-1053-05	LIQUID CRYSTAL	
C1			CC73GCH1H681J	CHIP C 680PF J	
C2 -4			CK73GB1C104K	CHIP C 0.10UF K	
C2 -4			CK73GB1H104K	CHIP C 0.10UF K	
C5 ,6			CK73GB1H103K	CHIP C 0.010UF K	
C8 -24			CK73GB1H103K	CHIP C 0.010UF K	
C25 ,26			CK73GB0J105K	CHIP C 1.0UF K	
C27			CK73GB1H222K	CHIP C 2200PF K	
287	3C		E29-1596-04	CONDUCTIVE RUBBER	
J1			E59-0835-05	RECTANGULAR PLUG (15P)	
L4			L40-1015-34	SMALL FIXED INDUCTOR (100UH)	
X1			L78-0556-05	RESONATOR (4.19MHZ)	
CP1			R90-1020-05	MULTI-COMP 22K X2	
CP3			R90-0723-05	MULTI-COMP 47K X2	
CP4			R90-0714-05	MULTI-COMP 10K X4	
CP5			R90-0726-05	MULTI-COMP 10K X2	
CP6			R90-0724-05	MULTI-COMP 1K X4	
CP7			R90-1022-05	MULTI-COMP 470 X2	
CP10			R90-0724-05	MULTI-COMP 1K X4	
CP11			R90-0718-05	MULTI-COMP 4.7K X4	
R2 ,3			RK73GB1J103J	CHIP R 10K J 1/16W	
R5 -7			RK73GB1J102J	CHIP R 1.0K J 1/16W	
R8			RK73FB2A101J	CHIP R 100 J 1/10W	
R9			RK73GB1J102J	CHIP R 1.0K J 1/16W	
R10			RK73GB1J223J	CHIP R 22K J 1/16W	
R11			RK73GB1J471J	CHIP R 470 J 1/16W	
R15			RK73GB1J104J	CHIP R 100K J 1/16W	
R16			RK73GB1J473J	CHIP R 47K J 1/16W	
R17			RK73GB1J103J	CHIP R 10K J 1/16W	
R18			RK73GB1J751J	CHIP R 750 J 1/16W	
R19			RK73GB1J433J	CHIP R 43K J 1/16W	
R20 -23			RK73GB1J222J	CHIP R 2.2K J 1/16W	
R24 -27			RK73EB2B331J	CHIP R 330 J 1/8W	
R28			RK73EB2B511J	CHIP R 510 J 1/8W	
R29 ,30			RK73EB2B561J	CHIP R 560 J 1/8W	
R31			RK73EB2B621J	CHIP R 620 J 1/8W	
R32 ,33			RK73EB2B561J	CHIP R 560 J 1/8W	
R34			RK73EB2B621J	CHIP R 620 J 1/8W	
R35 ,36			RK73EB2B561J	CHIP R 560 J 1/8W	
R37			RK73EB2B621J	CHIP R 620 J 1/8W	

Ref. No.	A d d	N e w	Parts No.	Description	Dest inati on
R38 ,39			RK73EB2B561J	CHIP R 560 J 1/8W	
R40			RK73EB2B621J	CHIP R 620 J 1/8W	
R41 -43			RK73GB1J473J	CHIP R 47K J 1/16W	
R44			RK73EB2B391J	CHIP R 390 J 1/8W	
R45			RK73EB2B331J	CHIP R 330 J 1/8W	
D24			MA3091-M	ZENER DIODE	
D26			DA204U	DIODE	
IC1			UPD780076GK501	MI-COM IC	
IC2			LC75878W	MOS-IC	
IC3			RS-171	ANALOGUE IC	
Q1			2SC2412K	TRANSISTOR	
Q1			2SD601A	TRANSISTOR	K1M2E2
Q2 ,3			2SD2114K	TRANSISTOR	
Q4			DTA144EUA	DIGITAL TRANSISTOR	
Q4			KRA304	DIGITAL TRANSISTOR	K1M2E2
Q5 -7			2SC2412K	TRANSISTOR	
Q5 -7			2SD601A	TRANSISTOR	K1M2E2
SUB-CIRCUIT UNIT (X16-118X-XX)					
290	2C		E58-0903-05	RECTANGULAR RECEPTACLE (15P)	
291	2C		J84-0121-12	FLEXIBLE PRINTED WIRING BOARD	
ELECTRIC UNIT (X25-87XX-XX)					
C1 ,2			C90-2606-05	ELECTRO 0.47UF 50WV	
C13 -16			C90-5296-05	NP-ELECT 0.22UF 50WV	
C17 ,18			C90-2597-05	ELECTRO 10UF 16WV	
C21 ,22			C90-2597-05	ELECTRO 10UF 16WV	
C23 ,24			C90-2606-05	ELECTRO 0.47UF 50WV	
C25			CE04CW1A470M	ELECTRO 47UF 10WV	
C33 ,34			CK73FB1E104K	CHIP C 0.10UF K	
C41			CK73GB1A474K	CHIP C 0.47UF K	
C42			CC73GCH1H151J	CHIP C 150PF J	
C43			CK73GB1E333K	CHIP C 0.033UF K	
C43			CK73GB1H333K	CHIP C 0.033UF K	
C44			CK73GB1H103K	CHIP C 0.010UF K	
C51			CK73GB1H222K	CHIP C 2200PF K	
C52			C90-5235-05	ELECTRO 2200UF 16WV	
C53			CK73GB1H103K	CHIP C 0.010UF K	
C54			C90-2594-05	ELECTRO 10UF 10WV	
C55			C90-2866-05	ELECTRO 220UF 16WV	
C56			CE04CW0J101M	ELECTRO 100UF 6.3WV	
C57			CE04CW1C101M	ELECTRO 100UF 16WV	
C58			CE04CW1A221M	ELECTRO 220UF 10WV	
C59			CE04CW1A101M	ELECTRO 100UF 10WV	
C71			CK73GB1H103K	CHIP C 0.010UF K	M2E2E1
C72			CK73GB1E223K	CHIP C 0.022UF K	
C72			CK73GB1H223K	CHIP C 0.022UF K	
C73			C90-2608-05	ELECTRO 1.0UF 50WV	
C74			C90-2602-05	ELECTRO 0.10UF 50WV	
C75			CK73GB1C683K	CHIP C 0.068UF K	
C75			CK73GB1H683K	CHIP C 0.068UF K	
C76			C90-2598-05	ELECTRO 3.3UF 25WV	
C77			CK73GB1H102K	CHIP C 1000PF K	
C78 -80			CK73GB1H103K	CHIP C 0.010UF K	
C83 -90			CK73GB1E473K	CHIP C 0.047UF K	

K1: KDC-V6017 E1: KDC-V6090R E2: KDC-V6090RY M2: KDC-V7018R

PARTS LIST

* New Parts

Parts without **Parts No.** are not supplied.

Les articles non mentionnes dans le **Parts No.** ne sont pas fournis.

Teile ohne **Parts No.** werden nicht geliefert.

ELECTRIC UNIT (X25-87XX-XX)

Ref. No.	A d d	N e w	Parts No.	Description	Dest inati on
C83 -90			CK73GB1H473K	CHIP C 0.047UF K	
C91			C90-2606-05	ELECTRO 0.47UF 50WV	
C92			CE04CW1C220M	ELECTRO 22UF 16WV	
C93			CK73GB1C104K	CHIP C 0.10UF K	
C93			CK73GB1H104K	CHIP C 0.10UF K	
C94			C90-2608-05	ELECTRO 1.0UF 50WV	
C101			C90-2610-05	ELECTRO 2.2UF 50WV	
C102			CK73GB1H153K	CHIP C 0.015UF K	
C103			CE04CW1A470M	ELECTRO 47UF 10WV	
C104			CK73GB1H103K	CHIP C 0.010UF K	
C105,106			CK73GB1C104K	CHIP C 0.10UF K	
C105,106			CK73GB1H104K	CHIP C 0.10UF K	
C112,113			CK73GB1H103K	CHIP C 0.010UF K	
C120			CK73GB1H103K	CHIP C 0.010UF K	
C135			CK73GB1H103K	CHIP C 0.010UF K	M2E2E1
C136			C90-2594-05	ELECTRO 10UF 10WV	M2E2E1
C137			CC73GCH1H331J	CHIP C 330PF J	M2E2E1
C138			C90-2594-05	ELECTRO 10UF 10WV	M2E2E1
C139,140			CC73GCH1H100D	CHIP C 10PF D	M2E2E1
C152			CK73GB1A224K	CHIP C 0.22UF K	
C154-157			CK73GB1H103K	CHIP C 0.010UF K	
C163			CK73GB1H103K	CHIP C 0.010UF K	
C201			CK73GB1H103K	CHIP C 0.010UF K	
C202			CE04CW0J470M	ELECTRO 47UF 6.3WV	
C203			CK73EBOJ106K	CHIP C 10UF K	
C204			CC73GCH1H220J	CHIP C 22PF J	
C205			CC73GCH1H270J	CHIP C 27PF J	
C206			CK73GB0J105K	CHIP C 1.0UF K	
C211			CK73GB1H102K	CHIP C 1000PF K	
CN1			E40-3241-05	PIN ASSY (6P)	
CN5			E40-9550-05	FLAT CABLE CONNECTOR (22P)	
CN6			E40-9557-05	FLAT CABLE CONNECTOR (13P)	
CN7			E40-5448-05	PIN ASSY (4P)	
△ J1	2D		E58-0863-15	RECTANGULAR RECEPTACLE (16P)	
J4			E56-0834-05	CYLINDRICAL RECEPTACLE (13P)	
WH1	2D		E30-4804-05	CORD WITH PLUG	
WH1	2D	*	E30-4932-05	CORD WITH PLUG	K1M2E2
L1			L33-1170-05	CHOKO COIL ASSY	
L2 -7			L40-4795-91	SMALL FIXED INDUCTOR(4.7UH,J)	
L8			L33-1123-05	LINE FILTER COIL (52mH)	
L12			L92-0075-05	CHIP FERRITE	
X1			L78-0821-05	RESONATOR (20MHz)	
X2			L77-2738-05	CRYSTAL RESONATOR (32.768kHz)	
X3			L77-2002-05	CRYSTAL RESONATOR (4.332MHz)	M2E2E1
M	2D		N83-3005-46	PAN HEAD TAPTITE SCREW	
P	2D		N80-3008-46	PAN HEAD TAPTITE SCREW	
Q	2D		N83-3012-46	PAN HEAD TAPTITE SCREW	
R	2D		N86-2606-46	BINDING HEAD TAPTITE SCREW	
R1 ,2			RK73GB1J361J	CHIP R 360 J 1/16W	
R3 ,4			RK73GB1J223J	CHIP R 22K J 1/16W	
R5 ,6			RK73EB2B181J	CHIP R 180 J 1/8W	
R13 ,14			RK73GB1J361J	CHIP R 360 J 1/16W	
R15 ,16			RK73GB1J223J	CHIP R 22K J 1/16W	

Ref. No.	A d d	N e w	Parts No.	Description	Dest inati on
R17 ,18			RK73EB2B181J	CHIP R 180 J 1/8W	
R19 -22			RK73GB1J103J	CHIP R 10K J 1/16W	
R23 ,24			RK73EB2B100J	CHIP R 10 J 1/8W	
R25			RK73EB2B4R7J	CHIP R 4.7 J 1/8W	
R41			RK73GB1J472J	CHIP R 4.7K J 1/16W	
R42			RK73GB1J103J	CHIP R 10K J 1/16W	
R51			RK73GB1J101J	CHIP R 100 J 1/16W	
R52			RD14BB2C223J	RD 22K J 1/6W	
R53			RK73GB1J222J	CHIP R 2.2K J 1/16W	
R54			RK73GB1J223J	CHIP R 22K J 1/16W	
R55			RK73FB2A103J	CHIP R 10K J 1/10W	
R56			RK73FB2A102J	CHIP R 1.0K J 1/10W	
R57			RK73GB1J102J	CHIP R 1.0K J 1/16W	
R58 ,59			RD14DB2H2R2J	SMALL-RD 2.2 J 1/2W	
R60			RD14BB2C152J	RD 1.5K J 1/6W	
R61			RD14BB2C102J	RD 1.0K J 1/6W	
R62			RK73EB2B2R2J	CHIP R 2.2 J 1/8W	
R71			RK73EB2B102J	CHIP R 1.0K J 1/8W	M2E2E1
R72			RK73FB2A561J	CHIP R 560 J 1/10W	M2E2E1
R73			RK73GB1J223J	CHIP R 22K J 1/16W	M2E2E1
R74			RK73EB2B103J	CHIP R 10K J 1/8W	M2E2E1
R76			RK73GB1J473J	CHIP R 47K J 1/16W	M2E2E1
R77			RK73GB1J104J	CHIP R 100K J 1/16W	
R78			RK73EB2B103J	CHIP R 10K J 1/8W	
R79 ,80			RD14DB2H102J	SMALL-RD 1.0K J 1/2W	
R81			RD14BB2C223J	RD 22K J 1/6W	
R82			RD14BB2C472J	RD 4.7K J 1/6W	M2
R82 ,83			RD14BB2C472J	RD 4.7K J 1/6W	K1E2E1
R84 ,85			RD14DB2H102J	SMALL-RD 1.0K J 1/2W	
R86			RK73FB2A223J	CHIP R 22K J 1/10W	K1
R87			RK73FB2A243J	CHIP R 24K J 1/10W	
R88 ,89			RK73GB1J103J	CHIP R 10K J 1/16W	
R90 ,91			RK73GB1J223J	CHIP R 22K J 1/16W	
R92			RD14BB2C333J	RD 33K J 1/6W	
R93			RD14DB2H332J	SMALL-RD 3.3K J 1/2W	
R94			RK73GB1J104J	CHIP R 100K J 1/16W	
R101			RK73GB1J103J	CHIP R 10K J 1/16W	
R102			RK73GB1J101J	CHIP R 100 J 1/16W	
R103			RK73GB1J103J	CHIP R 10K J 1/16W	
R105			RK73GB1J473J	CHIP R 47K J 1/16W	
R106			RK73GB1J152J	CHIP R 1.5K J 1/16W	
R108			RK73GB1J622J	CHIP R 6.2K J 1/16W	
R113			RK73GB1J472J	CHIP R 4.7K J 1/16W	
R114			RK73GB1J102J	CHIP R 1.0K J 1/16W	
R115			RK73GB1J472J	CHIP R 4.7K J 1/16W	
R121			RK73EB2B101J	CHIP R 100 J 1/8W	
R122-126			RK73EB2B472J	CHIP R 4.7K J 1/8W	
R127,128			RK73EB2B101J	CHIP R 100 J 1/8W	
R129,130			RK73GB1J104J	CHIP R 100K J 1/16W	
R141,142			RK73EB2B102J	CHIP R 1.0K J 1/8W	
R143,144			RK73GB1J223J	CHIP R 22K J 1/16W	
R145			RK73GB1J473J	CHIP R 47K J 1/16W	
R161			RK73GB1J102J	CHIP R 1.0K J 1/16W	M2E2E1
R162			RK73GB1J472J	CHIP R 4.7K J 1/16W	M2E2E1
R170-173			RK73GB1J104J	CHIP R 100K J 1/16W	

K1: KDC-V6017 E1: KDC-V6090R E2: KDC-V6090RY M2: KDC-V7018R

△ indicates safety critical components.

KDC-V6017, V6090R/RV, V7018R

PARTS LIST

* New Parts

Parts without **Parts No.** are not supplied.

Les articles non mentionnés dans le **Parts No.** ne sont pas fournis.

Teile ohne **Parts No.** werden nicht geliefert.

ELECTRIC UNIT (X25-87XX-XX)

Ref. No.	A d d	N e w	Parts No.	Description	Des t i n a t i o n
R174			RK73GB1J222J	CHIP R 2.2K J 1/16W	
R175			RK73EB2B471J	CHIP R 470 J 1/8W	
R177			RK73EB2B102J	CHIP R 1.0K J 1/8W	
R178			RK73GB1J472J	CHIP R 4.7K J 1/16W	
R179			RK73GB1J105J	CHIP R 1.0M J 1/16W	
R180			RK73EB2B472J	CHIP R 4.7K J 1/8W	
R181			RK73EB2B471J	CHIP R 470 J 1/8W	
R182			RK73GB1J473J	CHIP R 47K J 1/16W	
R183			RK73EB2B471J	CHIP R 470 J 1/8W	
R184,185			RK73EB2B102J	CHIP R 1.0K J 1/8W	
R187			RK73EB2B102J	CHIP R 1.0K J 1/8W	
R189			RK73GB1J471J	CHIP R 470 J 1/16W	
R190			RK73GB1J104J	CHIP R 100K J 1/16W	
R191			RK73GB1J471J	CHIP R 470 J 1/16W	
R192			RK73GB1J104J	CHIP R 100K J 1/16W	
R193,194			RK73GB1J471J	CHIP R 470 J 1/16W	
R201			RK73GB1J221J	CHIP R 220 J 1/16W	
R202			RK73GB1J103J	CHIP R 10K J 1/16W	
R204-209			RK73GB1J102J	CHIP R 1.0K J 1/16W	
R210			RK73GB1J222J	CHIP R 2.2K J 1/16W	
R213,214			RK73GB1J104J	CHIP R 100K J 1/16W	K1
R214			RK73GB1J104J	CHIP R 100K J 1/16W	M2E2E1
R215			RK73GB1J471J	CHIP R 470 J 1/16W	
R219,220			RK73GB1J222J	CHIP R 2.2K J 1/16W	
R223,224			RK73GB1J104J	CHIP R 100K J 1/16W	
R225			RK73GB1J102J	CHIP R 1.0K J 1/16W	
R226			RK73GB1J222J	CHIP R 2.2K J 1/16W	
R227,228			RK73GB1J102J	CHIP R 1.0K J 1/16W	
R229			RK73GB1J104J	CHIP R 100K J 1/16W	
R230,231			RK73GB1J471J	CHIP R 470 J 1/16W	
R232			RK73GB1J104J	CHIP R 100K J 1/16W	
R233-236			RK73GB1J222J	CHIP R 2.2K J 1/16W	M2E2E1
R236			RK73GB1J222J	CHIP R 2.2K J 1/16W	K1
R237			RK73GB1J104J	CHIP R 100K J 1/16W	K1
R239-242			RK73GB1J104J	CHIP R 100K J 1/16W	K1
R239,240			RK73GB1J104J	CHIP R 100K J 1/16W	M2E2E1
R243			RK73GB1J222J	CHIP R 2.2K J 1/16W	
R245			RK73GB1J104J	CHIP R 100K J 1/16W	
R246			RK73GB1J473J	CHIP R 47K J 1/16W	
R247			RK73GB1J102J	CHIP R 1.0K J 1/16W	
R252,253			RK73GB1J102J	CHIP R 1.0K J 1/16W	
R254			RK73GB1J222J	CHIP R 2.2K J 1/16W	
R255			RK73GB1J225J	CHIP R 2.2M J 1/16W	
R258,259			RK73GB1J471J	CHIP R 470 J 1/16W	
R260			RK73GB1J102J	CHIP R 1.0K J 1/16W	
R261,262			RK73GB1J472J	CHIP R 4.7K J 1/16W	
R263,264			RK73GB1J103J	CHIP R 10K J 1/16W	
R269			RK73GB1J104J	CHIP R 100K J 1/16W	K1M2
R270,271			RK73GB1J104J	CHIP R 100K J 1/16W	E2E1
R271			RK73GB1J104J	CHIP R 100K J 1/16W	K1
R272,273			RK73GB1J104J	CHIP R 100K J 1/16W	M2
R273			RK73GB1J104J	CHIP R 100K J 1/16W	K1E2E1
R275			RK73GB1J104J	CHIP R 100K J 1/16W	
R281			RK73GB1J104J	CHIP R 100K J 1/16W	
R282			RK73GB1J103J	CHIP R 10K J 1/16W	

Ref. No.	A d d	N e w	Parts No.	Description	Des t i n a t i o n
W51 -56			R92-1252-05	CHIP R 0 OHM	K1M2
W51 -58			R92-1252-05	CHIP R 0 OHM	E2E1
W58			R92-1252-05	CHIP R 0 OHM	K1M2
D1			RM10ZLF	DIODE	
D2			MA4056(N)-M	ZENER DIODE	
D3			1GWJ43	DIODE	
D4			MA4091(N)-L	ZENER DIODE	
D5			HZS9A2L	ZENER DIODE	K1M2E2
D5			MA4082(N)-L	ZENER DIODE	
D6		*	HZS11B2	ZENER DIODE	K1M2E2
D6			MA4110-L	ZENER DIODE	
D11			HZS6B1	ZENER DIODE	M2E2
D11			MA4056-M	ZENER DIODE	M2E2E1
D12			HZS5B1	ZENER DIODE	M2E2
D12			MA4047-M	ZENER DIODE	M2E2E1
D13			AM01Z	DIODE	
D13			DSM1SD2	DIODE	
D13			ERA15-02	DIODE	
D14			1SS133	DIODE	
D15,16			AM01Z	DIODE	K1E2E1
D15,16			DSM1SD2	DIODE	K1E2E1
D15,16			ERA15-02	DIODE	K1E2E1
D16			AM01Z	DIODE	M2
D16			DSM1SD2	DIODE	M2
D16			ERA15-02	DIODE	M2
D17,18			MA4068(N)-M	ZENER DIODE	
D21 -28			AM01Z	DIODE	
D21 -28			DSM1SD2	DIODE	
D21 -28			ERA15-02	DIODE	
D30 -34			1SS133	DIODE	
D35,36			MA4068(N)-M	ZENER DIODE	
D37			IMSA-6801	SURGE ABSORBER	K1M2E2
D37			SA-C2012-101TB	SURGE ABSORBER	E1
D41,42			HZS6C1	ZENER DIODE	K1M2E2
D41,42			MA4062-L	ZENER DIODE	
D44			HZS6C1	ZENER DIODE	K1M2E2
D44			MA4062-L	ZENER DIODE	
D45 -47			MA4068(N)-M	ZENER DIODE	
D71			1SS133	DIODE	
IC1		*	UPD703033GC076	MI-COM IC	
IC2			TDA7407D	ANALOGUE IC	
IC3			HD74HC02FP	MOS-IC	K1M2E2
IC3			TC74HC02AF	IC	
IC4			TA8263BH	ANALOGUE IC	
IC7			TDA7479D	ANALOGUE IC	M2E2E1
IC8			S-80837ANNP	MOS-IC	
Q1,2			DTC143TUA	DIGITAL TRANSISTOR	
Q1,2		*	KRC410	DIGITAL TRANSISTOR	K1M2E2
Q5,6			DTC143TUA	DIGITAL TRANSISTOR	
Q5,6		*	KRC410	DIGITAL TRANSISTOR	K1M2E2
Q7			DTA124EUA	DIGITAL TRANSISTOR	
Q7		*	KRA303	DIGITAL TRANSISTOR	K1M2E2
Q11			2SC4081	TRANSISTOR	
Q11			2SD1819A	TRANSISTOR	K1M2E2

K1: KDC-V6017 E1: KDC-V6090R E2: KDC-V6090RY M2: KDC-V7018R

KDC-V6017, V6090R/RV, V7018R

PARTS LIST

* New Parts

Parts without **Parts No.** are not supplied.

Les articles non mentionnes dans le **Parts No.** ne sont pas fournis.

Teile ohne **Parts No.** werden nicht geliefert.

ELECTRIC UNIT (X25-87XX-XX)

Ref. No.	A d d	N e w	Parts No.	Description	Dest inati on
Q12			2SB1548(P)	TRANSISTOR	
Q13			2SA1576A	TRANSISTOR	
Q13			2SB1218A	TRANSISTOR	K1M2E2
Q14			2SC4081	TRANSISTOR	
Q14			2SD1819A	TRANSISTOR	K1M2E2
Q15			2SB1548(P)	TRANSISTOR	
Q16			DTC124EUA	DIGITAL TRANSISTOR	
Q16			UN5212	DIGITAL TRANSISTOR	K1M2E2
Q17			DTA124EUA	DIGITAL TRANSISTOR	
Q17		*	KRA303	DIGITAL TRANSISTOR	K1M2E2
Q18			2SD2375	TRANSISTOR	
Q19			DTC124EUA	DIGITAL TRANSISTOR	
Q19			UN5212	DIGITAL TRANSISTOR	K1M2E2
Q20			DTA124EUA	DIGITAL TRANSISTOR	
Q20		*	KRA303	DIGITAL TRANSISTOR	K1M2E2
Q21			2SB1184	TRANSISTOR	
Q22			2SC4081	TRANSISTOR	
Q22			2SD1819A	TRANSISTOR	K1M2E2
Q25			DTA123JK	DIGITAL TRANSISTOR	M2E2E1
Q25			KRA105S	DIGITAL TRANSISTOR	M2E2
Q26			DTC144EUA	DIGITAL TRANSISTOR	
Q26			UN5213	DIGITAL TRANSISTOR	K1M2E2
Q27			DTC114YUA	DIGITAL TRANSISTOR	M2E2E1
Q27			UN5214	DIGITAL TRANSISTOR	M2E2
Q27 ,28			DTC114YUA	DIGITAL TRANSISTOR	K1
Q27 ,28			UN5214	DIGITAL TRANSISTOR	K1
Q29			DTA124EUA	DIGITAL TRANSISTOR	
Q29		*	KRA303	DIGITAL TRANSISTOR	K1M2E2
Q30			2SA1576A	TRANSISTOR	
Q30			2SB1218A	TRANSISTOR	K1M2E2
Q31 ,32			2SB1277(Q,R)	TRANSISTOR	K1
Q32			2SB1277(Q,R)	TRANSISTOR	M2E2E1
Q33 ,34			2SC4081	TRANSISTOR	
Q33 ,34			2SD1819A	TRANSISTOR	K1M2E2
Q42			DTC124EUA	DIGITAL TRANSISTOR	
Q42			UN5212	DIGITAL TRANSISTOR	K1M2E2
Q43			2SC4081	TRANSISTOR	
Q43			2SD1819A	TRANSISTOR	K1M2E2
Q45 ,46			DTC124EUA	DIGITAL TRANSISTOR	
Q45 ,46			UN5212	DIGITAL TRANSISTOR	K1M2E2
Q47 ,48			2SB1277(Q,R)	TRANSISTOR	
Q51			DTC144EUA	DIGITAL TRANSISTOR	
Q51			UN5213	DIGITAL TRANSISTOR	K1M2E2
Q52			2SC4081	TRANSISTOR	M2E2E1
Q52			2SD1819A	TRANSISTOR	M2E2
Q55			2SA1576A	TRANSISTOR	
Q55			2SB1218A	TRANSISTOR	K1M2E2
Q56			DTC124EUA	DIGITAL TRANSISTOR	
Q56			UN5212	DIGITAL TRANSISTOR	K1M2E2
TH1			PTH9C42BD471Q	POSITIVE RESISTOR	
A1	3D		X86-3240-11	TUNER UNIT	K1
A1	3D		X86-3242-70	TUNER UNIT	M2E2
A1	3D		X86-3342-71	TUNER UNIT	E1

Ref. No.	A d d	N e w	Parts No.	Description	Dest inati on
CD PLAYER UNIT (X32-5030-00)					
C1 ,2			CK73FB1C105K	CHIP C	1.0UF K
C3			CK73FB0J475K	CHIP C	4.7UF K
C4			C92-0566-05	CHIP-TAN	10UF 6.3WV
C5			CC73GCH1H150J	CHIP C	15PF J
C6			CC73GCH1H020C	CHIP C	2.0PF C
C7			CK73GB1C104K	CHIP C	0.10UF K
C8			CK73FB1C105K	CHIP C	1.0UF K
C10			CK73GB1H472K	CHIP C	4700PF K
C11			CK73GB1H682K	CHIP C	6800PF K
C12			CK73GB1H332K	CHIP C	3300PF K
C13			CK73GB1C333K	CHIP C	0.033UF K
C14			CK73GB1H472K	CHIP C	4700PF K
C15			CK73GB1C473K	CHIP C	0.047U K
C16			CC73GCH1H151J	CHIP C	150PF J
C17			CK73GB1H472K	CHIP C	4700PF K
C18			CC73GCH1H221J	CHIP C	220PF J
C19 ,20			CK73GB1C104K	CHIP C	0.10UF K
C21			CK73FB0J475K	CHIP C	4.7UF K
C23			CK73GB1H102K	CHIP C	1000PF K
C24			CK73GB1E223K	CHIP C	0.022UF K
C25			CK73GB1H153K	CHIP C	0.015UF K
C26			CK73GB0J105K	CHIP C	1.0UF K
C28			CK73GB0J105K	CHIP C	1.0UF K
C29			CK73GB1C104K	CHIP C	0.10UF K
C33 -35			CK73GB1C104K	CHIP C	0.10UF K
C41			CK73EB1C225K	CHIP C	2.2UF K
C43			CK73GB1H153K	CHIP C	0.015UF K
C45			CK73GB1H153K	CHIP C	0.015UF K
C46			CK73GB1C473K	CHIP C	0.047UF K
C51			CK73FB1C105K	CHIP C	1.0UF K
C55			CK73GB1C104K	CHIP C	0.10UF K
C63			C92-1359-05	CHIP-TAN	10UF 16WV
C67 ,68			CK73GB0J105K	CHIP C	1.0UF K
C71 ,72			CK73GB1H471K	CHIP C	470PF K
C77 ,78			CC73GCH1H680J	CHIP C	68PF J
C79 ,80			CK73GB1H222K	CHIP C	2200PF K
C85			CK73GB1C104K	CHIP C	0.10UF K
C89			CK73GB1H222K	CHIP C	2200PF K
CN1			E40-9536-05	FLAT CABLE CONNECTOR (16P)	
CN2			E40-9339-05	FLAT CABLE CONNECTOR (22P)	
CN2			E41-0036-05	FLAT CABLE CONNECTOR (22P)	
CN2			E41-0129-05	FLAT CABLE CONNECTOR (22P)	
X1			L78-0572-05	RESONATOR	(16.93MHZ)
CP1 -3			R90-1019-05	MULTI-COMP	100 X2
R3			RK73GB1J272J	CHIP R	2.7K J 1/16W
R5			RK73GB1J361J	CHIP R	360 J 1/16W
R6			RK73GB1J272J	CHIP R	2.7K J 1/16W
R8			RK73EB2B4R7J	CHIP R	4.7 J 1/8W
R9			RK73EB2B100J	CHIP R	10 J 1/8W
R10 ,11			RK73GB1J103J	CHIP R	10K J 1/16W
R12			RK73GB1J912J	CHIP R	9.1K J 1/16W
R15			RK73GB1J824J	CHIP R	820K J 1/16W

K1: KDC-V6017 E1: KDC-V6090R E2: KDC-V6090RY M2: KDC-V7018R

△ indicates safety critical components.

KDC-V6017, V6090R/RV, V7018R

PARTS LIST

* New Parts

Parts without **Parts No.** are not supplied.

Les articles non mentionnés dans le **Parts No.** ne sont pas fournis.

Teile ohne **Parts No.** werden nicht geliefert.

CD PLAYER UNIT (X32-5030-00)

Ref. No.	A d d	N e w	Parts No.	Description	Dest inati on
R16			RK73GB1J223J	CHIP R 22K J 1/16W	
R17			RK73GB1J433J	CHIP R 43K J 1/16W	
R18			RK73GB1J392J	CHIP R 3.9K J 1/16W	
R19			RK73GB1J513J	CHIP R 51K J 1/16W	
R20			RK73GB1J104J	CHIP R 100K J 1/16W	
R21			RK73GB1J244J	CHIP R 240K J 1/16W	
R32			RK73GB1J104J	CHIP R 100K J 1/16W	
R34			RK73GB1J683J	CHIP R 68K J 1/16W	
R36			RK73GB1J151J	CHIP R 150 J 1/16W	
R37			RK73GB1J471J	CHIP R 470 J 1/16W	
R38			RK73GB1J224J	CHIP R 220K J 1/16W	
R44			RK73GB1J512J	CHIP R 5.1K J 1/16W	
R45			RK73GB1J103J	CHIP R 10K J 1/16W	
R46			RK73GB1J102J	CHIP R 1.0K J 1/16W	
R47			RK73GB1J103J	CHIP R 10K J 1/16W	
R49			RK73GB1J472J	CHIP R 4.7K J 1/16W	
R52			RK73GB1J104J	CHIP R 100K J 1/16W	
R54			RK73GB1J104J	CHIP R 100K J 1/16W	
R71			RK73GB1J103J	CHIP R 10K J 1/16W	
R72			RK73GB1J102J	CHIP R 1.0K J 1/16W	
R73			RK73GB1J473J	CHIP R 47K J 1/16W	
R75			RK73GB1J333J	CHIP R 33K J 1/16W	
R76			RK73GB1J622J	CHIP R 6.2K J 1/16W	
R77			RK73GB1J563J	CHIP R 56K J 1/16W	
R78			RK73GB1J243J	CHIP R 24K J 1/16W	
R81			RK73GB1J333J	CHIP R 33K J 1/16W	
R82			RK73GB1J123J	CHIP R 12K J 1/16W	
R83			RK73GB1J102J	CHIP R 1.0K J 1/16W	
R101,102			RK73GB1J332J	CHIP R 3.3K J 1/16W	
R103,104			RK73GB1J562J	CHIP R 5.6K J 1/16W	
R107,108			RK73FB2A331J	CHIP R 330 J 1/10W	
R117,118			RK73FB2A203J	CHIP R 20K J 1/10W	
R121,122			RK73FB2A203J	CHIP R 20K J 1/10W	
R125,126			RK73FB2A203J	CHIP R 20K J 1/10W	
R202			RK73GB1J104J	CHIP R 100K J 1/16W	
R213			RK73GB1J104J	CHIP R 100K J 1/16W	
R218			RK73GB1J473J	CHIP R 47K J 1/16W	
R233			RK73GB1J622J	CHIP R 6.2K J 1/16W	
R234			RK73GB1J103J	CHIP R 10K J 1/16W	
W17			R92-2053-05	CHIP R 0 J 1/8W	
S1 ,2			S68-0838-05	PUSH SWITCH	
S3			S68-0859-05	PUSH SWITCH	
D1 ,2			DAN202U	DIODE	
D3			DA204U	DIODE	
D4			DAN202U	DIODE	
IC1			AN22000AA	ANALOGUE IC	
IC2		*	MN662773KF1	MOS-IC	
IC4			BA5917AFP	ANALOGUE IC	
IC5			TA78L05F	IC(VOLTAGE REGULATOR/ +5V)	
IC6			NJM4565MD	IC(OP AMP X2)	
Q1			MCH6101	TRANSISTOR	
Q2			DTC124EUA	DIGITAL TRANSISTOR	
Q3 ,4			2SA1362(Y)	TRANSISTOR	
Q5			DTC124EUA	DIGITAL TRANSISTOR	

Ref. No.	A d d	N e w	Parts No.	Description	Dest inati on
MECHANISM ASSY (X92-4100-00)					
1	2A		A10-4482-01	CHASSIS	
2	1B		A10-4225-33	CHASSIS CALKING ASSY	
3	2B		A11-0915-43	SUB CHASSIS CALKING ASSY	
5	2A		D10-3082-13	ARM	
6	2A		D10-4306-14	ARM ASSY	
7	2A		D10-4305-14	ARM ASSY	
8	3A		D10-3087-44	ARM ASSY	
9	3B		D10-3092-03	SLIDER	
10	3B		D10-3093-04	SLIDER ASSY	
11	2B		D10-3095-04	SLIDER ASSY	
12	2B		D10-3096-04	SLIDER ASSY	
13	1A		D10-3099-24	SLIDER ASSY	
14	1A		D10-3100-04	SLIDER ASSY	
16	1B		D10-4004-04	LEVER ASSY	
17	1B		D10-4006-04	LEVER	
18	1A		D10-4007-04	LEVER	
19	2B		D10-4008-14	LEVER	
20	2A		D10-4009-23	ARM	
21	3A		D10-4010-04	LEVER	
22	3A		D10-4307-04	LEVER ASSY	
24	3B		D10-4050-04	ARM	
25	2A		D10-4038-23	ARM ASSY	
26	2A		D10-4123-24	LEVER ASSY	
27	3A		D13-1442-03	RACK (GEAR)	
29	3B		D13-1231-04	GEAR	
30	3A		D13-1240-04	GEAR	
31	3B		D13-1233-04	GEAR	
32	3B		D13-1234-14	GEAR ASSY	
33	3A		D13-1441-03	GEAR	
34	3B		D13-1232-04	GEAR	
35	3B		D13-1241-04	GEAR	
36	3A		D13-1242-04	GEAR	
37	1B		D13-1243-04	GEAR	
38	1B		D13-1244-04	GEAR	
39	1B		D13-1245-14	GEAR	
40	2A		D13-1246-04	GEAR	
41	2B		D13-1247-04	GEAR	
43	2B		D13-1249-04	GEAR ASSY	
44	2B		D13-1341-04	GEAR ASSY (LEAD SCREW)	
45	1B		D14-0668-04	ROLLER	
46	2A		D14-0670-04	ROLLER	
47	3B		D14-0674-04	ROLLER	
49	3A		D21-2228-14	SHAFT	
50	1A		D21-2229-04	SHAFT	
51	1A		D23-0925-24	RETAINER	
52	2A		D32-0614-04	STOPPER	
53	1B		D39-0223-05	DAMPER (YEL)	
54	2B		D39-0224-05	DAMPER (BLK)	
55	3B		F09-1246-04	SHEET	
58	3B		F09-1266-14	SHEET	
60	2A		G01-2770-04	EXTENSION SPRING	
61	3A		G01-2771-04	EXTENSION SPRING	

K1: KDC-V6017 E1: KDC-V6090R E2: KDC-V6090RY M2: KDC-V7018R

KDC-V6017, V6090R/RV, V7018R

SPECIFICATIONS

	Model	KDC-V6017	KDC-V7018R	KDC-V6090R/RV
FM	Frequency Range (Frequency step)	87.9MHz~107.9MHz (200kHz)	87.5MHz~108.0MHz (50kHz)	87.5MHz~108.0MHz (50kHz)
	Channel Space Selection	50kHz/200kHz	50kHz	-
	Usable Sensitivity (S/N 26dB)	-	-	0.7 μ V/75 Ω
	Usable Sensitivity (S/N 30dB)	9.3dBf (0.8 μ V/75 Ω)	0.7 μ V/75 Ω	-
	Quieting Sensitivity (S/N 46dB)	-	-	1.6 μ V/75 Ω
	Quieting Sensitivity (S/N 50dB)	15.2dBf (1.6 μ V/75 Ω)	1.6 μ V/75 Ω	-
	Frequency Response (\pm 3.0dB)	30Hz~15kHz	30Hz~15kHz	30Hz~15kHz
	S/N	70dB (MONO)	65dB (MONO)	65dB (MONO)
	Selectivity	\geq 80dB (\pm 400kHz)	\geq 80dB (\pm 400kHz)	-
	Selectivity (DIN)	-	-	\geq 80dB (\pm 400kHz)
	Stereo Separation	40dB (1kHz)	35dB (1kHz)	35dB (1kHz)
AM (MW)	Frequency Range (Frequency step)	530kHz~1700kHz (10kHz)	531kHz~1611kHz (9kHz)	531kHz~1611kHz (9kHz)
	Channel Space Selection	9kHz/10kHz	-	-
	Usable Sensitivity (S/N 20dB)	28dB μ (25 μ V)	25 μ V	25 μ V
LW	Frequency Range	-	153kHz~281kHz	153kHz~281kHz
	Usable Sensitivity (S/N 20dB)	-	45 μ V	45 μ V
CD	Laser Diode	GaAlAs (λ =780nm)	GaAlAs (λ =780nm)	GaAlAs (λ =780nm)
	Digital Filter (D/A)	8 Times Over Sampling	8 Times Over Sampling	8 Times Over Sampling
	D/A Converter	1 Bit	1 Bit	1 Bit
	Spindle Speed	500~200rpm (CLV)	500~200rpm (CLV)	500~200rpm (CLV)
	Wow & Flutter	Below Measurable Limit	Below Measurable Limit	Below Measurable Limit
	Frequency Response	10Hz~20kHz (\pm 1dB)	10Hz~20kHz (\pm 1dB)	10Hz~20kHz (\pm 1dB)
	THD	0.01% (1kHz)	0.01% (1kHz)	0.01% (1kHz)
	S/N Ratio	93dB (1kHz)	93dB (1kHz)	93dB (1kHz)
	Dynamic Range	93dB	93dB	93dB
	Channel Separation	85dB	85dB	85dB
Pre-out Level/Load (Unbalanced)		1800mV/10k Ω (CD/CD-CH)	1800mV/10k Ω (CD/CD-CH)	1800mV/10k Ω (CD/CD-CH)
Pre-out Impedance		\leq 600 Ω	\leq 600 Ω	\leq 600 Ω
AMPLIFIER	Maximum Power	47Wx4	47Wx4	47Wx4
	Full Bandwidth Power (at less than 1% THD)	22Wx4	22Wx4	-
	Power DIN45324, +B=14.4V	-	-	29Wx4
TONE	Bass	100Hz \pm 10dB	100Hz \pm 10dB	100Hz \pm 10dB
	Middle	1kHz \pm 10dB	1kHz \pm 10dB	1kHz \pm 10dB
	Treble	10kHz \pm 10dB	10kHz \pm 10dB	10kHz \pm 10dB
GENERAL	Operating Voltage (11V~16V allowable)	14.4V	14.4V	14.4V
	Current Consumption	10A	10A	10A
	Installation Size (W)	182mm 7-3/16inch	182mm	182mm
	(H)	53mm 2-1/16inch	53mm	53mm
	(D)	162mm 6-5/16inch	162mm	162mm
	Weight	1.7kg (4.0lbs)	1.7kg	1.7kg

KENWOOD follows a policy of continuous advancements in development. For this reason specifications may be changed without notice.

KENWOOD CORPORATION

14-6, Dogenzaka 1-chome, Shibuya-ku, Tokyo 150-8501 Japan

KENWOOD SERVICE CORPORATION
P.O. BOX 22745, 2201 East Dominguez Street, Long Beach, CA90801-5745, U.S.A.

KENWOOD ELECTRONICS CANADA INC.
6070 Kestrel Road, Mississauga, Ontario, Canada L5T 1S8

KENWOOD ELECTRONICS LATIN AMERICA S.A.
P.O. Box 55-2791 Paillilla, Plaza Credicorp Bank Panama,
Piso 9, Oficina 901, Calle 50, Panama, Rep. de Panama

KENWOOD ELECTRONICS BRASIL LTDA.
Av. Moema, 170-17, Andar-Cobertura "B", Ed. Maximum Service Center, 04077-020
Moema, São Paulo-SP-Brasil

KENWOOD ELECTRONICS UK LIMITED
Kenwood House, Dwight Road, Watford, Herts, WD1 8EB, United Kingdom

KENWOOD ELECTRONICS DEUTSCHLAND GMBH
Rembrücker-Str. 15, 63150 Heusenstamm, Germany

KENWOOD ELECTRONICS FRANCE S.A.
13, Boulevard Ney, 75018 Paris, France

KENWOOD ELECTRONICS BELGIUM N.V.
Mechelsesteenweg 418, B-1930 Zaventem, Belgium

KENWOOD ELECTRONICS ITALIA S.p.A.
Via G. Sirtori 7/9, 20129 Milano, Italy

KENWOOD IBÉRICA S.A.
Bolivia, 239-08020 Barcelona, Spain

KENWOOD ELECTRONICS AUSTRALIA PTY. LTD. (A.C.N. 001 499 074)
16 Giffnock Avenue, Centrecourt Estate, North Ryde,
N.S.W. 2113, Australia

KENWOOD ELECTRONICS (HONG KONG) LTD.
Unit 3712-3724, Level 37, Tower 1, Metroplaza, 223 Hing Fong Road, Kwai Fong, N.T.,
Hong Kong

KENWOOD ELECTRONICS GULF FZE
P.O. Box 61318, Jebel Ali, Dubai, U.A.E.

KENWOOD ELECTRONICS (THAILAND) CO., LTD.
2019 New Pechburi Road, Bangkok, Huaykwang, Bangkok, 10320 Thailand

KENWOOD ELECTRONICS SINGAPORE PTE. LTD.
1 Genting Lane, #07-00, Kenwood Building, Singapore, 349544

KENWOOD ELECTRONICS (MALAYSIA) SDN BHD
#4.01 Level 4, Wisma Academy Lot 4A, Jalan 19/1, 46300 Petaling Jaya, Selangor Darul Ehsan,
Malaysia